

D Series Gear Motors Including Fan Drive

Technical Information

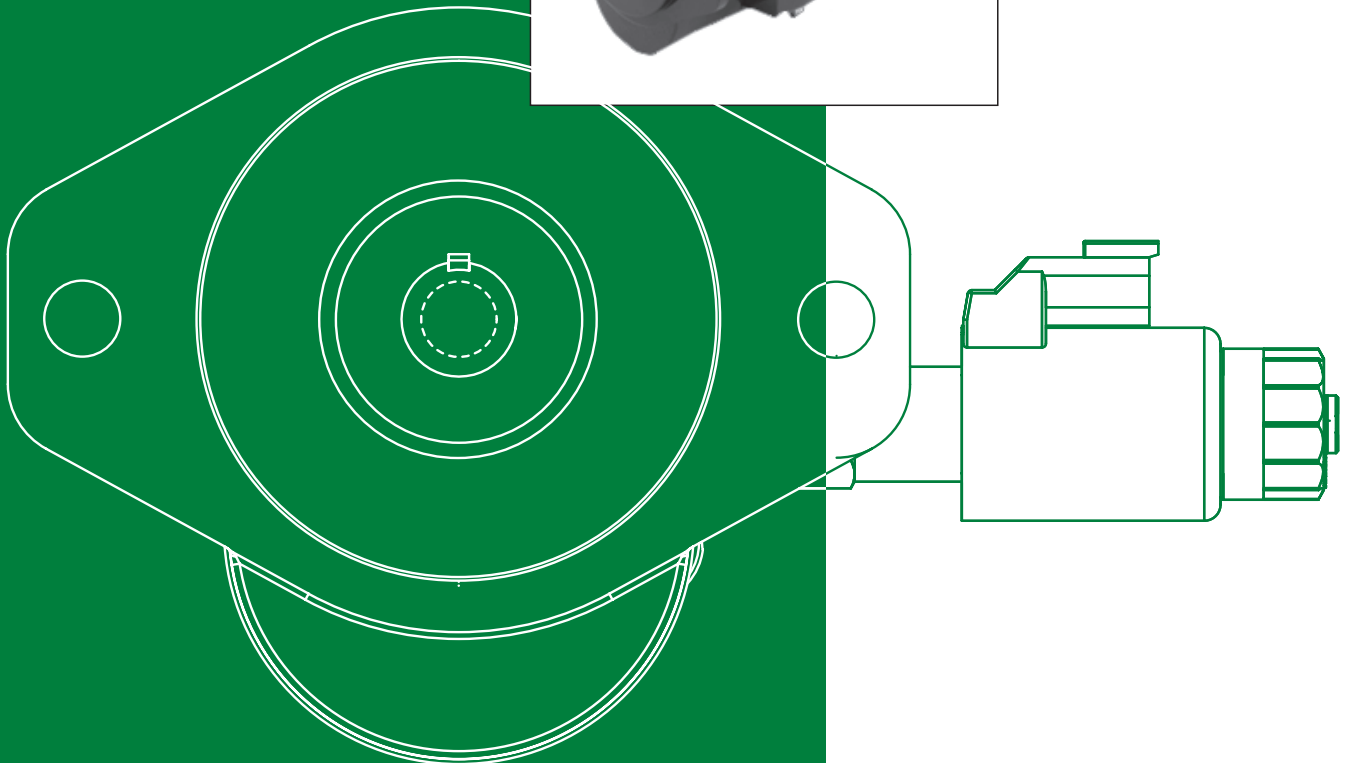

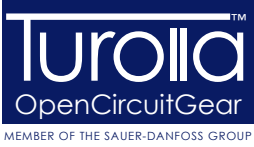

D Series Gear Motors Including Fan Drive

Technical Information

Revisions

History of Revisions

Table of Revisions

Date	Page	Changed	Rev.
February 2009	-	First edition	AA
November 2009	25	TY shaft uses a #8 woodruff key	AB
February 2010	last	Fix Osaka address	AC
April 2010	various	Add reversing fan drive motor	BA
November 2010	all	Turolla colors	CA
July 2011	All	TurollaOCG new layout, fonts update, Sauer-Danfoss replacement.	D
October 2011	1	Cover page change	E

© 2011 Turolla OpenCircuitGear™. All rights reserved.

TurollaOCG accepts no responsibility for possible errors in catalogs, brochures and other printed material. TurollaOCG reserves the right to alter its products without prior notice. This also applies to products already ordered provided that such alterations can be made without affecting agreed specifications. All trademarks in this material are properties of their respective owners. Sauer-Danfoss, Turolla, Turolla OpenCircuitGear, TurollaOCG, OpenCircuitGear, Fast Lane and PLUS+1 are trademarks of the Sauer-Danfoss Group.

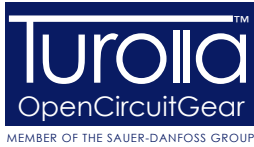

D Series Gear Motors Including Fan Drive

Technical Information

Contents

General Information

Overview	5
Features and Benefits	5
Fan Drive Motors	5
Features	6
Benefits	6
System Schematics	7
Product Features.....	8
Technical Specifications.....	9
Fluid Specifications.....	9
Sizing Equations	10

Operating Parameters

Overview	11
Pressure.....	11
Peak Pressure.....	11
Rated Pressure	11
System Pressure.....	11
Back Pressure.....	11
Case Drain Pressure.....	11
Temperature and Viscosity.....	12
Speed.....	12
Temperature	12
Viscosity.....	12
Hydraulic Fluid.....	13
Filtration.....	13
Filters	13
Selecting a Filter	13
Reservoir.....	14
Line Sizing	14
Motor Life.....	14
Motor Shaft Connection	15
Radial and Axial Loading	15

Model Code

Order Code	16
Fan drive motor code example.....	16

Dimension Drawings

Mounting Flanges	21
Shaft Options	22
Port Options	23
Selecting Port Options	24
Integrated Reversing Motor with Proportional Relief and Shock/Anti-cavitation Valves.....	25

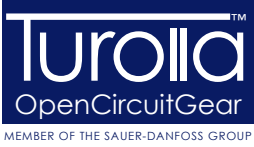

D Series Gear Motors Including Fan Drive

Technical Information

Contents

Options

Standard Relief Valve.....	27
Anti-cavitation Check Valve	29
Proportional Relief Valve with Anti-cavitation Valve	30
Valve Settings	31
Performance Graphs	32
Valve Settings	32
Fan Drive Motor	34
Fan Drive Motor Example:.....	34
Standard Motor	35
Standard Motor Example:	35
Standard Motor with Split Flange Ports	36
Integrated Reversing Motor with Proportional Relief and Shock/Anti-cavitation Valves ..	37

Performance Data

Motor Performance Graphs	39
--------------------------------	----

Reference Literature

TurollaOCG Fan Drive Related Literature	41
---	----

D Series Gear Motors Including Fan Drive Technical Information General Information

Overview

The TurolloOCG D Series fixed displacement gear motor has been specifically designed for demanding mobile equipment applications where maximum performance is required at peak power levels and operating temperatures. The D Series motor is available in displacements of 14cm³ to 45cm³ [0.87 in³ to 2.75 in³]. This motor delivers consistent efficiency across the entire operating range of pressure, speed, and temperature; all in an industry-leading package size that maximizes power density.

Features and Benefits

- High strength cast iron construction allows consistently efficient performance in continuous operation at 276 bar (4000 psi) and 110°C (230°F).
- Custom engineered shaft bearings and dual pressure-balanced thrust plates optimize internal bearing lubrication, allowing for high starting torque and long life with fluid viscosities as low as 8 mm²/sec (cSt) [36 SUS].
- Compact three-piece design with bearings located in the front flange and rear cover minimizes the overall package length and increases radial load carrying capability, eliminating the need for outrigger bearings on most applications.
- Variety of integrated valve options make the D Series motor ideally suited for high performance fan drive applications.

Fan Drive Motors

D Series cast iron motors complement the TurolloOCG portfolio of fan drive products. Including aluminum and cast iron pumps and motors, piston pumps and motors, valves and microcontrollers, you can apply the TurolloOCG range in various combinations to create high-performance fan drive systems. D series motors with integrated reversing and proportional relief valves are PLUS+1TM compliant for easy plug-and-performTM installations and offer precise control of fan speed to optimize engine cooling performance.

Quick reference chart - TurolloOCG fan drive motors

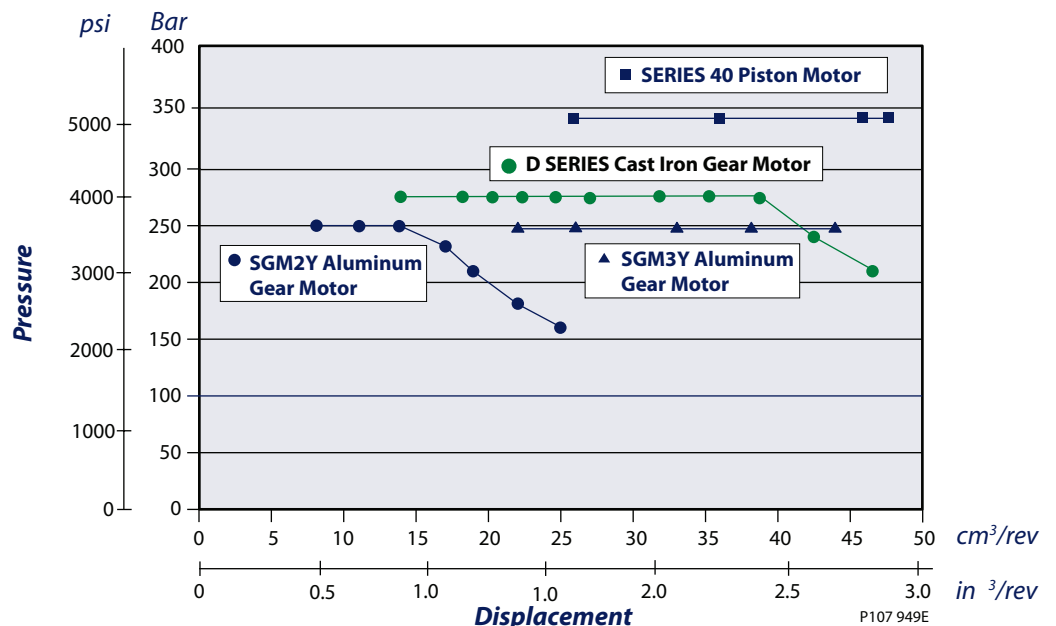

D Series Gear Motors Including Fan Drive

Technical Information

General Information

Features

Quality components and construction

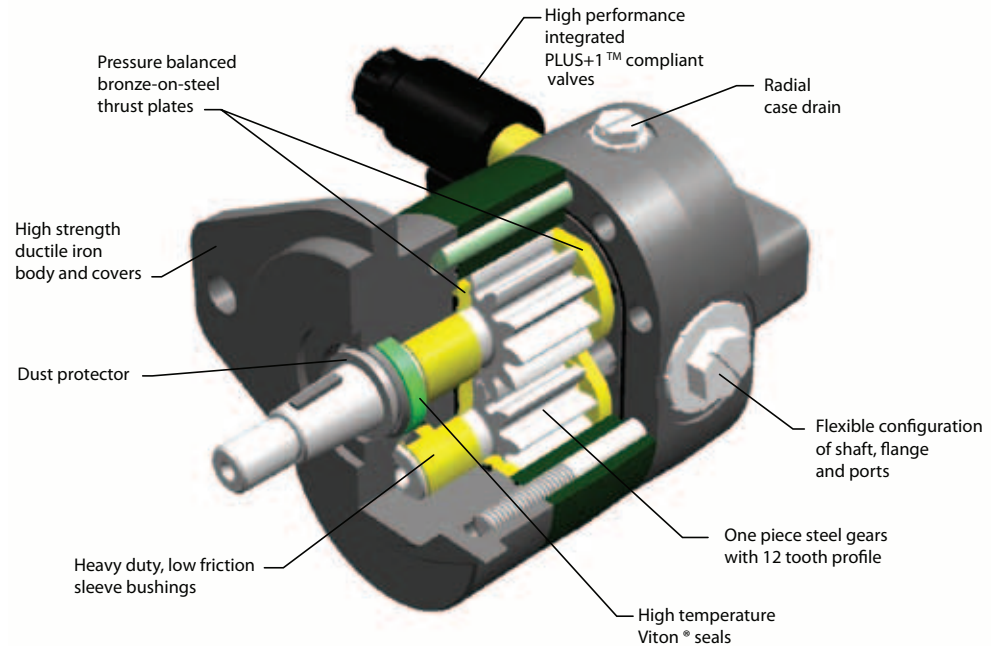

P107 920E

Benefits

- Pressure-balanced thrust plates for improved efficiency at extreme pressures and temperatures
- High-temperature Viton® seals for today's hotter running machines
- Three-piece ductile iron construction for increased durability, increased power density, with reduced adverse efficiency effects at high temperatures.
- High quality steel backed bronze bearings for maximum pressure handling capacity, located in the front flange, allowing extended radial loading capacity without an external roller bearing.
- Output shaft external dust seal to protect the oil seal from contamination damage
- Available side or rear ports, SAE A or B flange, with a variety of shafts for versatility.
- Integrated, normally-closed electrohydraulic proportional relief valve option for today's high-performing fan systems.

System Schematics

Gear pump/gear motor system with electronic control

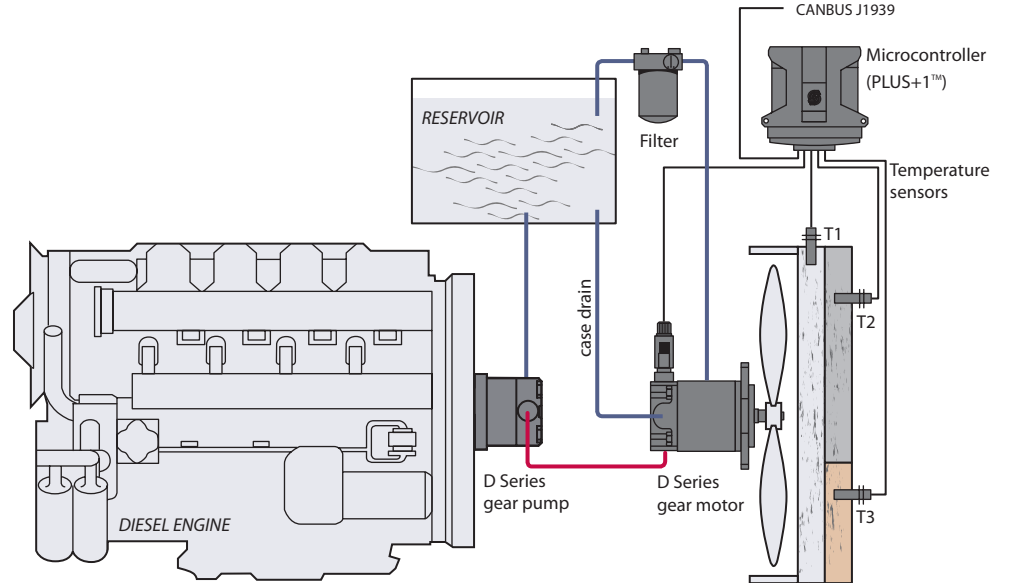

P107 929E

Piston pump/gear motor system with electronic control

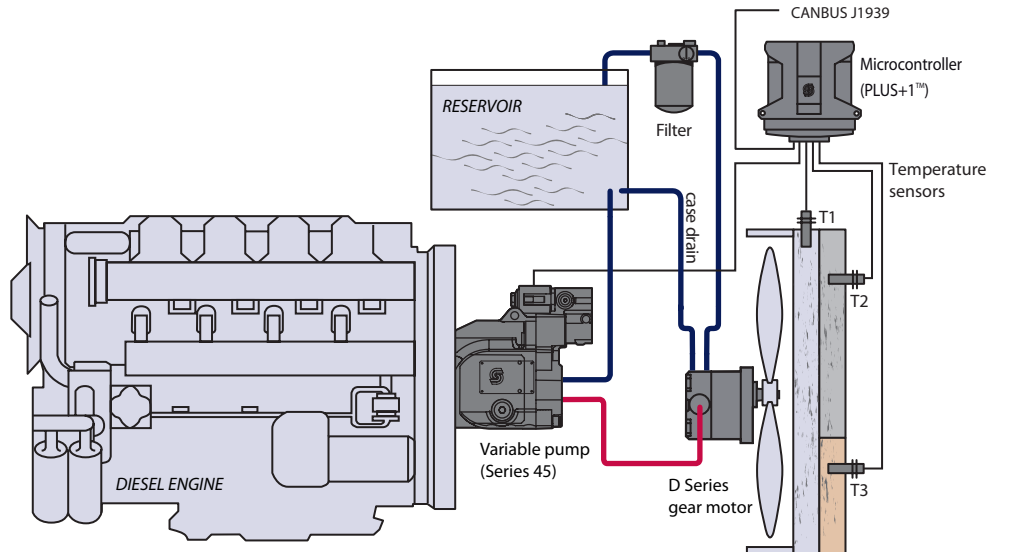

P107 931E

D Series Gear Motors Including Fan Drive

Technical Information

General Information

System Schematics (continued)

Gear pump/gear motor system with integrated reversing valve

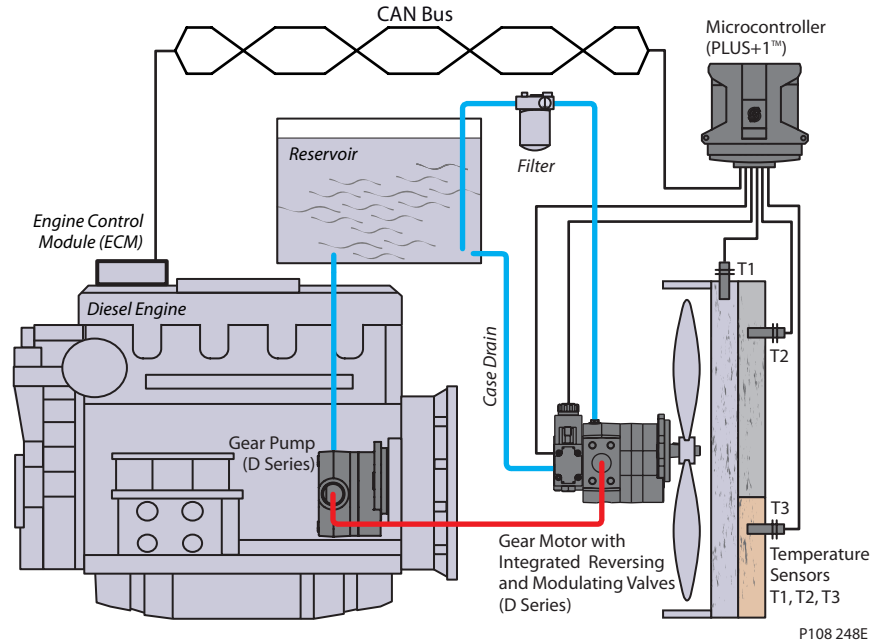

Product Features

Features	Description
Construction	Heavy duty ductile iron 3-piece construction
Displacements	14 to 45 cm ³ [0.87 to 2.75 in ³ /rev]
Continuous Pressure	276 bar [4000 psi] to 38 cm ³ [2.32 in ³ /rev]
Peak Pressure	303 bar [4400 psi] to 38 cm ³ [2.32 in ³ /rev]
Speed	600 to 3400 min ⁻¹ (rpm) - up to 38cm ³
Mounting	SAE A two bolt, SAE B two bolt
Shaft (types)	SAE straight keyed, 1:8 tapered keyed, splined
Fluid viscosity	8 mm ² /sec (cSt) [36 SUS] minimum, 1600 mm ² /sec (cSt) [7500 SUS] maximum
Filtration requirement	22/18/13 ISO 4406 at motor inlet
Inlet options	SAE O-ring boss, SAE split flange
Fluids	Petroleum/mineral based
Operating temperature	-40°C [-40°F] minimum for cold start 110°C [230°F] normal operating conditions 115°C [239°F] peak intermittent
Integrated valve options	Proportional relief valve, normally closed, 12 Vdc and 24 Vdc two position directional control valve, 12 Vdc and 24 Vdc Relief valve Anti-cavitation check valve

Technical Specifications

Technical data for D Motors

Ratings	Units	14	17	19	21	23	25	29	32	36	38	41	45
Displacement	cm ³ /rev	14.3	17.0	19.0	20.5	22.5	25.4	29.0	31.8	36.1	38.0	41.0	45.0
	in ³ /rev	0.87	1.04	1.16	1.25	1.37	1.55	1.77	1.94	2.20	2.32	2.50	2.75
Rated pressure	bar	276	276	276	276	276	276	276	276	276	276	241	210
	psi	4000	4000	4000	4000	4000	4000	4000	4000	4000	4000	3495	3045
Peak pressure	bar	303	303	303	303	303	303	303	303	303	303	265	231
	psi	4400	4400	4400	4400	4400	4400	4400	4400	4400	4400	3843	3350
Speed at rated pressure	maximum	3400	3400	3400	3400	3400	3400	3400	3400	3400	3400	3000	3000
	minimum*	600	600	600	600	600	600	600	600	600	600	600	600
Start speed at 1000 PSI	rpm	400	400	400	400	400	400	400	400	400	400	400	400
Standard Weight	kg	8.46	8.53	8.66	8.80	8.94	9.07	9.38	9.53	9.84	9.93	10.16	10.43
	lb	18.7	18.8	19.1	19.4	19.7	20.0	20.7	21.0	21.7	21.9	22.4	23.0
Mass moment of inertia of internal rotating components	x10 ⁻⁶ kg·m ²	113	127	138	146	156	172	191	206	228	239	255	276
	x10 ⁻⁶ slug·ft ²	83	94	102	107	115	127	141	152	168	176	188	204
Theoretical torque at rated pressure	N·m	62.6	65.7	73.4	79.2	87.0	98.2	112.1	122.9	139.6	146.9	138.4	132.4
	lbf·ft	46.2	48.5	54.2	58.4	64.2	72.4	82.7	90.7	102.9	108.3	102.1	97.6
Theoretical power at rated speed	kW	22.3	23.4	26.1	28.2	31.0	35.0	39.9	43.8	49.7	46.1	43.5	41.6
	hp	29.9	31.2	34.9	37.6	41.3	46.6	53.2	58.4	66.3	61.1	58.0	55.5
Case drain pressure	bar	5	5.0	5.0	5.0	5.0	5.0	5.0	5.0	5.0	5.0	5.0	5.0
	psi	72.5	72.5	72.5	72.5	72.5	72.5	72.5	72.5	72.5	72.5	72.5	72.5

* minimum speed at maximum pressure

Fluid Specifications

Parameter	Unit	Minimum	Continuous	Maximum
Viscosity	mm ² /sec (cSt)	8	10 - 100	1600
	[SUS]	[36]	[50 - 212]	[7500]
Temperature	°C [°F]	-40 [-40]	110 [230]	115 [239]
Cleanliness		ISO 4406 Class 22/18/13 or better		
Filtration efficiency	charge filtration	$\beta_{15-20}=75(\beta_{10}\geq 10)$		

Ratings are based on operation with premium petroleum-based hydraulic fluids containing oxidation, rust, and foam inhibitors.

Sizing Equations

Use these formulas to determine the nominal motor size for a specific application.

Based on SI units

Input flow $Q = \frac{V_g \cdot n}{1000 \cdot \eta_v}$ (l/min)

Output torque $M = \frac{V_g \cdot \Delta p \cdot \eta_m}{20 \cdot \pi}$ (N·m)

Output power $P = \frac{M \cdot n}{9550} = \frac{Q \cdot \Delta p \cdot \eta_t}{600}$ (kW)

Motor speed $n = \frac{Q \cdot 1000 \cdot \eta_v}{V_g}$ (min⁻¹(rpm))

Based on US units

$Q = \frac{V_g \cdot n}{231 \cdot \eta_v}$ (US gal/min)

$M = \frac{V_g \cdot \Delta p \cdot \eta_m}{2 \cdot \pi}$ (lbf·in)

$P = \frac{Q \cdot \Delta p \cdot \eta_t}{1714} = \frac{M \cdot n}{63\,025}$ (hp)

$n = \frac{Q \cdot 231 \cdot \eta_v}{V_g}$ (min⁻¹(rpm))

Variables SI units [US units]

V_g	= Displacement per revolution	cm ³ /rev [in ³ /rev]
p_o	= Outlet pressure	bar [psi]
p_i	= Inlet pressure	bar [psi]
Δp	= $p_o - p_i$ (system pressure)	bar [psi]
n	= Speed	min ⁻¹ (rpm)
η_v	= Volumetric efficiency	
η_m	= Mechanical efficiency	
η_t	= Overall efficiency ($\eta_v \cdot \eta_m$)	

D Series Gear Motors Including Fan Drive Technical Information Operating Parameters

Overview

Definitions of the D Series operating parameters appear below. Consult your TurolldOCG representative for applications running outside of these parameters.

Pressure

Peak Pressure

Peak pressure is the highest intermittent pressure allowed. The relief valve overshoot (reaction time) determines peak pressure. It is assumed to occur for less than 100 ms. The illustration to the right shows peak pressure in relation to rated pressure and reaction time (100 ms maximum).

Pressure vs. time

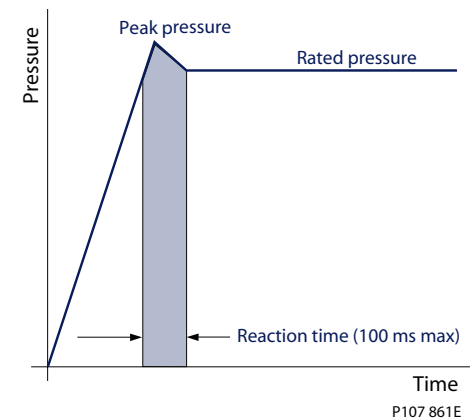

Rated Pressure

Rated pressure is the average, regularly occurring operating inlet pressure that should yield satisfactory product life. The maximum machine load at the motor shaft determines rated pressure.

System Pressure

System pressure is the differential between the inlet and outlet ports. It is a dominant operating variable affecting hydraulic unit life. High system pressure, resulting from high load at the motor shaft, reduces expected life. System pressure must remain at, or below, rated pressure during normal operation to achieve expected life.

Back Pressure

The hydraulic load downstream of the motor determines the back pressure. The D Series motor can work with back pressure up to 100% of the maximum rated inlet pressure.

Case Drain Pressure

Case drain pressure is the pressure in the case drain line. Route case drain plumbing directly to the reservoir to keep the case drain pressure as low as possible. Maximum continuous case drain pressure allowed is 5 bar [72.5 psi].

D Series Gear Motors Including Fan Drive

Technical Information

Operating Parameters

Temperature and Viscosity

Temperature and viscosity requirements must be concurrently satisfied.

Temperature

High temperature limits apply at the inlet port of the motor. Ensure the motor runs at or below the maximum continuous temperature.

Cold oil, generally, does not affect the durability of motor components. It may affect the ability of oil to flow and transmit power. For this reason, keep the temperature at 16°C [60 °F] above the pour point of the hydraulic fluid.

Minimum (cold start) **temperature** relates to the physical properties of component materials.

Continuous temperature is the temperature at or below which you may expect normal motor life.

Maximum temperature is the highest temperature that is tolerable by the machine for a transient/limited time. (Duty cycle 1% or less)

Viscosity

Minimum viscosity occurs only during brief occasions of maximum fluid temperature and severe duty cycle operation. It's the minimum acceptable viscosity to guarantee the motor life. (Duty cycle 1% or less)

Maximum viscosity occurs only during cold start at very low temperatures. It is the upper limit of viscosity that allows the motor to start.

Continuous viscosity: The viscosity range at which you may expect normal motor.

Speed

Maximum speed is the limit for a particular gear motor when operating at rated pressure. It is the highest speed at which you may expect normal life.

The lower limit of operating speed is the **minimum speed**.

Minimum speed increases as operating system pressure increases. When operating under higher pressures, a higher minimum speed must be maintained, as shown.

Speed versus pressure

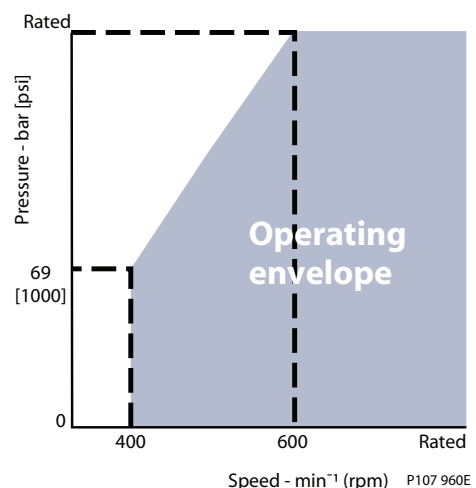

D Series Gear Motors Including Fan Drive

Technical Information

Operating Parameters

Hydraulic Fluid

Ratings and data for gear motors are based on operation with premium hydraulic fluids containing oxidation, rust, and foam inhibitors. These fluids must possess good thermal and hydrolytic stability to prevent wear, and corrosion of internal components. Use petroleum/mineral-based fluids. Ensure only clean fluid enters the hydraulic system.

ⓘ Caution

Never mix hydraulic fluids.

For more information on hydraulic fluid selection, see TurollaOCG publication **L1021414** *Hydraulic Fluids and Lubricants, Technical Information*.

Filtration

Filters

Use a filter that conforms to Class 22/18/13 of ISO 4406 (or better). It may be on the motor outlet (discharge filtration) or inlet (pressure filtration).

Selecting a Filter

When selecting a filter, please consider:

- Contaminant ingress rate (determined by factors such as the number of actuators used in the system)
- Generation of contaminants in the system
- Required fluid cleanliness
- Desired maintenance interval
- Filtration requirements of other system components

Measure filter efficiency with a Beta ratio (β_x). β_x ratio is a measure of filter efficiency defined by ISO 4572. It is the ratio of the number of particles greater than a given diameter (in microns) upstream of the filter to the number of these particles downstream of the filter.

- For discharge filtration with controlled reservoir ingress, use a $\beta_{35-45} = 75$ filter
- For pressure filtration, use a filtration with an efficiency of $\beta_{10} = 75$

Every system is unique. Only a thorough testing and evaluation program can fully validate the filtration system.

Fluid cleanliness level and β_x ratio

Fluid cleanliness level (per ISO 4406)	Class 22/18/13 or better
β_x ratio (discharge filtration)	$\beta_{35-45} = 75$ and $\beta_{10} = 2$
$\beta_{35-45} = 75$ and $\beta_{10} = 2$	$\beta_{10} = 75$
Recommended inlet screen size	100 – 125 μm [0.0039 – 0.0049 in]

D Series Gear Motors Including Fan Drive

Technical Information

Operating Parameters

Reservoir

The reservoir provides clean fluid, dissipates heat, removes entrained air, and allows for fluid volume changes associated with fluid expansion. A correctly sized reservoir accommodates maximum volume changes during all system operating modes. It promotes de-aeration of the fluid as it passes through, and accommodates a fluid dwell-time between 60 and 180 seconds, allowing entrained air to escape.

Minimum reservoir capacity depends on the volume required to cool and hold the fluid, allowing for expansion due to temperature changes. A fluid volume of one to three times the motor output flow (per minute) is satisfactory. The minimum recommended reservoir capacity is 125% of the fluid volume.

Put the return-line below the lowest expected fluid level to allow discharge into the reservoir for maximum dwell and efficient de-aeration. A baffle (or baffles) between the return and suction ports promotes de-aeration and accommodates fluid surges.

Line Sizing

Choose pipe sizes that accommodate minimum fluid viscosity to reduce system noise, pressure drops and overheating in order to maximize system life and performance. Line velocity should not exceed 5.0 m/s [16.4 ft/s]. Route case drain line direct to tank.

Most systems use hydraulic oil containing 10% dissolved air by volume. Over-aeration, or entrained air is the result of flow line restrictions, where the dissolved air comes out of solution, or when air is allowed to leak into the hydraulic circuit. These include inadequate pipe sizes, sharp bends, or elbow fittings, causing reduction of flow-line cross-sectional area. This problem will not occur if these circuit recommendations are followed, rated speed requirements are maintained, and reservoir size and location are adequate.

Motor Life

Motor life is a function of speed, system pressure, and other system parameters (such as fluid quality and cleanliness).

All TurollaOCG gear motors use hydrodynamic journal bearings that rely on an oil film between the gear shaft and bearing surfaces at all times. You can expect long life when this film is sustained through proper system maintenance and operating within recommended limits.

A B_{10} bearing life expectancy number is generally associated with rolling element bearings. It does not exist for hydrodynamic bearings.

High pressure impacts motor life. When submitting an application for review, provide machine duty cycle data that includes percentages of time at various loads and speeds. We strongly recommend a prototype testing program to verify operating parameters and their impact on life expectancy before finalizing any system design.

D Series Gear Motors Including Fan Drive Technical Information Operating Parameters

Motor Shaft Connection

Shaft options for gear motors include tapered, splined, and parallel shafts.

Plug-in drives, with a splined shaft, can impose severe radial loads when the mating spline is rigidly supported. Increasing spline clearance does not alleviate this condition.

Use plug-in drives only if the concentricity between the mating spline and pilot diameter is within 0.1 mm [0.004 in]. Lubricate the drive by flooding with oil. A three-piece coupling minimizes radial or thrust shaft loads.

Motor shaft connection

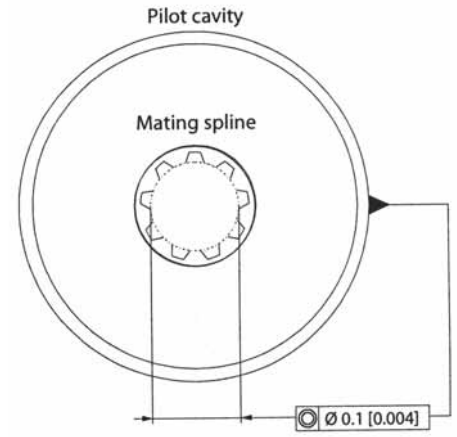

To avoid spline shaft damage, use carburized and hardened steel couplings with 80-82 HRA surface hardness.

Radial and Axial Loading

Allowable radial shaft loads are a function of the load position, load orientation, and operating pressure. All external shaft loads have an effect on bearing life, and may affect motor performance.

In applications where external shaft loads cannot be avoided, minimize the impact on the motor by optimizing the orientation and magnitude of the load. Avoid thrust loads in either direction. The table below shows the preferred orientation for radial loads assuming maximum pressure. For assistance concerning shaft loading, contact your TuroliaOCG representative.

Shaft axial and radial load ratings

Ratings	Units	14	17	19	21	23	25	29	32	36	38	41	45
Max. radial load at 12:00 +	lbf	1510	1430	1360	1300	1210	1070	870	700	420	270	450	620
	N	6717	6361	5943	1783	5382	4760	3870	3114	1868	1201	2002	2758
Push/Pull axial load	lbf	350	350	350	350	350	350	350	350	350	350	350	350
	N	1557	1557	1557	1557	1557	1557	1557	1557	1557	1557	1557	1557

Shaft loading

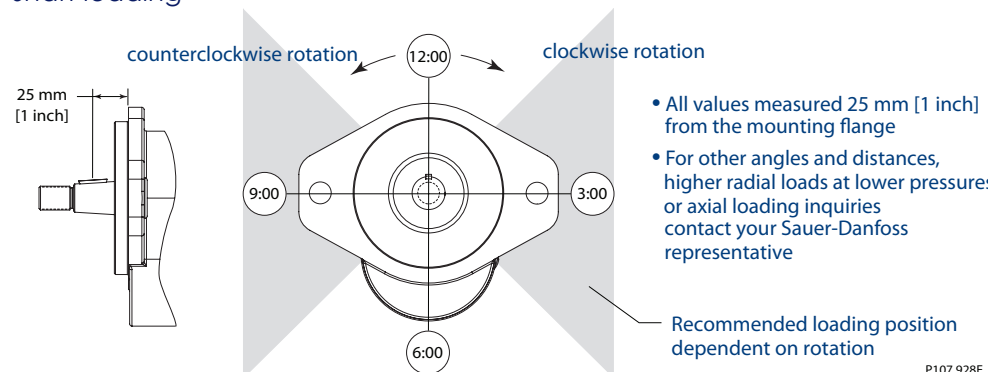

D Series Gear Motors Including Fan Drive

Technical Information

Model Code

Order Code

Fan drive motor code example

DEMR-17TY-AA-B107-P1AB-A000-N000-AN-NNN

A Right hand rotation, **B** 17 cm³, 1:8 taper shaft, **C** SAE A two bolt mounting, **D** 7/8-14 ports, idler side drain, **E** 12 Vdc proportional relief valve, 25 US gal/min or less at 172 bar curve, **F** anti-cavitation valve.



A Sense of rotation

Code	Description
B	Bidirectional rotation (reversing valve)
L	Left hand rotation (CCW)
R	Right hand rotation (CW)

B1 Displacement

Code	Description
14	14.3 cm ³ /rev [0.87 in ³ /rev]
17	17.0 cm ³ /rev [1.04 in ³ /rev]
19	19.0 cm ³ /rev [1.16 in ³ /rev]
21	20.5 cm ³ /rev [1.25 in ³ /rev]
23	22.5 cm ³ /rev [1.37 in ³ /rev]
25	25.4 cm ³ /rev [1.55 in ³ /rev]

Code	Description
29	29.0 cm ³ /rev [1.77 in ³ /rev]
32	31.8 cm ³ /rev [1.94 in ³ /rev]
36	36.1 cm ³ /rev [2.20 in ³ /rev]
38	38.0 cm ³ /rev [2.32 in ³ /rev]
41	41.0 cm ³ /rev [2.50 in ³ /rev]
45	45.1 cm ³ /rev [2.75 in ³ /rev]

B2 Input shaft

Code	Description
PB	SAE 22 mm [7/8 in] Ø x 41mm [1.62 in] Extension, 1/4 in key, with key
PW	SAE 22 mm [7/8 in] Ø x 51mm [2 in] Extension, 1/4 in key, with key
TY	SAE 1:8 taper, 22 mm [7/8 in] Ø x 59 mm [2.34 in] Extension, 5/8-18 x 21 mm [.81 in] external thread with #8 Woodruff key
TK	1:8 taper, 22 mm [7/8 in] Ø x 35 mm [1.38 in] Extension, 3/8-24 x 19 mm [.75 in] Internal thread
SM	11 tooth, 48 mm [1.89 in] extension, (modified length) 30 mm [1.20 in] effective spline
SH	13 tooth, 41 mm [1.62 in] length

C Mounting

Code	Description
AA	SAE A, 2 bolt
BB	SAE B, 2 Bolt

D1 Rear Cover Function

Code	Description
N	No valves, standard cover
A	Cover with anti-cavitation check valve
B	Cover for use with low flow relief valve (P1, P3 or F) and anti-cavitation check valve
C	Cover for use with high flow relief valve (P2, P4 or G) and anti-cavitation check valve
P	Cover with empty SAE 12-2 cavity and anti-cav ity (customer supplied) relief valve
S	Cover with empty SAE 10-2 cavity and anti-cav ity (customer supplied) relief valve
R	Cover for reversing function with proportional relief, primary CW rotation
L	Cover for reversing function with proportional relief, primary CW rotation

For the D module, the **first number** specifies the function of the rear cover.

D Series Gear Motors Including Fan Drive

Technical Information

Model Code

Order Code (continued)



For the D module, the next three numbers specify the port options for the rear cover.

D2 Rear Cover Port Options

Code		Description	
Radial	Axial	Inlet/Outlet	Drain port
105	505	3/4-16 SAE O-ring boss	Radial 9/16-18 SAE (idler side*)
106	506	3/4-16 SAE O-ring boss	Radial 9/16-18 SAE (drive side*)
107	507	7/8-14 SAE O-ring boss	Radial 9/16-18 SAE (idler side*)
108	508	7/8-14 SAE O-ring boss	Radial 9/16-18 SAE (drive side*)
109	509	1 1/16-12 SAE O-ring boss	Radial 9/16-18 SAE (idler side*)
110	510	1 1/16-12 SAE O-ring boss	Radial 9/16-18 SAE (drive side*)
111	N/A	1 5/16-12 SAE O-ring boss	Radial 9/16-18 SAE (idler side*)
112	N/A	1 5/16-12 SAE O-ring boss	Radial 9/16-18 SAE (drive side*)
330	N/A	1inch SAE Split flange	Radial 9/16-18 SAE (idler side*)
331	N/A	1inch SAE Split flange	Radial 9/16-18 SAE (drive side*)
332	N/A	1-1/4 SAE Split flange	Radial 9/16-18 SAE (idler side*)
333	N/A	1-1/4 SAE Split flange	Radial 9/16-18 SAE (drive side*)

* See dimension drawings for explanation of drive and idler side.

D Rear Cover Availability Matrix

Code	D1 Rear cover/valve option								
	D2 Port options	N	B	C	A	P	S	R	L
105	●	—	—	●	—	—	—	—	—
106	●	—	—	●	—	—	—	—	—
107	●	●	●	●	●	●	●	●	●
108	●	●	●	●	●	●	●	●	●
109	●	●	●	●	●	●	●	●	●
110	●	●	●	●	●	●	●	●	●
111	●	●	●	●	●	●	●	●	●
112	●	●	●	●	●	●	●	●	●
330/331	●	—	—	●	—	—	—	●	●
332/333	●	—	—	●	—	—	—	●	●
505	●	—	—	●	—	—	—	—	—
506	●	—	—	●	—	—	—	—	—
507	●	—	—	●	—	—	—	—	—
508	●	—	—	●	—	—	—	—	—
509	●	—	—	●	—	—	—	—	—
510	●	—	—	●	—	—	—	—	—

Legend:	
●	Standard
○	Optional
—	Not Available

Order Code (continued)



E Relief Valve Availability

Code	Description	Pressure bar [psi]	Compatible with D1 - Rear cover function							
			N	B	C	A	P	S	R	L
N000	No relief valve	N/A	●	—	—	●	●	●	—	—
R000	Reversing, with proportional relief	See module G	—	—	—	—	—	—	●	●
F138	F style - low flow, fixed setting pressure relief valve (non-reversing)	138 [2000]	—	●	—	—	—	—	—	—
F172		172 [2500]	—	●	—	—	—	—	—	—
F207		207 [3000]	—	●	—	—	—	—	—	—
F241		241 [3500]	—	●	—	—	—	—	—	—
F276		276 [4000]	—	●	—	—	—	—	—	—
G138	G style - high flow, fixed setting pressure relief valve (non-reversing)	138 [2000]	—	—	●	—	—	—	—	—
G172		172 [2500]	—	—	●	—	—	—	—	—
G207		207 [3000]	—	—	●	—	—	—	—	—
G241		241 [3500]	—	—	●	—	—	—	—	—
G276		276 [4000]	—	—	●	—	—	—	—	—
P1AA	P1 style - low flow, proportional relief valve 12 Vdc (non-reversing)	138 [2000]	—	●	—	—	—	—	—	—
P1AB		172 [2500]	—	●	—	—	—	—	—	—
P1AC		207 [3000]	—	●	—	—	—	—	—	—
P1AD		241 [3500]	—	●	—	—	—	—	—	—
P1AF		276 [4000]	—	●	—	—	—	—	—	—
P2BA	P2 style - high flow, proportional relief valve 12 Vdc (non-reversing)	138 [2000]	—	—	●	—	—	—	—	—
P2BB		172 [2500]	—	—	●	—	—	—	—	—
P2BC		207 [3000]	—	—	●	—	—	—	—	—
P2BD		241 [3500]	—	—	●	—	—	—	—	—
P2BF		276 [4000]	—	—	●	—	—	—	—	—
P3AA	P3 style - low flow, proportional relief valve 24 Vdc (non-reversing)	138 [2000]	—	●	—	—	—	—	—	—
P3AB		172 [2500]	—	●	—	—	—	—	—	—
P3AC		207 [3000]	—	●	—	—	—	—	—	—
P3AD		241 [3500]	—	●	—	—	—	—	—	—
P3AF		276 [4000]	—	●	—	—	—	—	—	—
P4BA	P4 style - high flow, proportional relief valve 24 Vdc (non-reversing)	138 [2000]	—	—	●	—	—	—	—	—
P4BB		172 [2500]	—	—	●	—	—	—	—	—
P4BC		207 [3000]	—	—	●	—	—	—	—	—
P4BD		241 [3500]	—	—	●	—	—	—	—	—
P4BF		276 [4000]	—	—	●	—	—	—	—	—

Legend:	
●	Standard
○	Optional
—	Not Available

D Series Gear Motors Including Fan Drive

Technical Information

Model Code

Order Code
(continued)



F Anti-cavitation/Shock Valve Function

		Compatible with D1 - Rear cover option							
	F	A	B	C	N	P	S	R	L
No valves	N000				●	—	—	—	—
Anti-cavitation valve	A000	●	●	●		●	●		
Shock with Anti-cavitation	S300	—	—	—	—	—	—	●	●

Units with integrated reversing are bi-directional motors, however, valves are rotation specific. User must specify **DEMB** rotation and **R** or **L** rear cover. Integrated reversing also requires **R000** relief and **S300** anti-cavitation/shock valves.

G Integrated Reversing Modulating Function

Code	Description	Pressure bar [psi]	A	B	C	N	P	S	R	L
N000	No integrated reversing valve	N/A	●	●	●	●	●	●	—	—
A1AA	D03 Directional Valve P1 Style - Proportional relief valve 12 VDC	138 [2000]	—	—	—	—	—	—	●	●
A1AB		172 [2500]	—	—	—	—	—	—	●	●
A1AC		207 [3000]	—	—	—	—	—	—	●	●
A1AD		241 [3500]	—	—	—	—	—	—	●	●
A1AF		276 [4000]	—	—	—	—	—	—	●	●
A2AA	D03 Directional Valve P3 Style - Proportional relief valve 24 VDC	138 [2000]	—	—	—	—	—	—	●	●
A2AB		172 [2500]	—	—	—	—	—	—	●	●
A2AC		207 [3000]	—	—	—	—	—	—	●	●
A2AD		241 [3500]	—	—	—	—	—	—	●	●
A2AF		276 [4000]	—	—	—	—	—	—	●	●
B1AA	D05 Directional Valve P2 Style - Proportional relief valve 12 VDC	138 [2000]	—	—	—	—	—	—	●	●
B1AB		172 [2500]	—	—	—	—	—	—	●	●
B1AC		207 [3000]	—	—	—	—	—	—	●	●
B1AD		241 [3500]	—	—	—	—	—	—	●	●
B1AF		276 [4000]	—	—	—	—	—	—	●	●
B2AA	D05 Directional Valve P4 Style - Proportional relief valve 24 VDC	138 [2000]	—	—	—	—	—	—	●	●
B2AB		172 [2500]	—	—	—	—	—	—	●	●
B2AC		207 [3000]	—	—	—	—	—	—	●	●
B2AD		241 [3500]	—	—	—	—	—	—	●	●
B2AF		276 [4000]	—	—	—	—	—	—	●	●

Legend:	
●	Standard
○	Optional
—	Not Available

D Series Gear Motors Including Fan Drive Technical Information Model Code

Order Code (continued)



H Name Plate

Code	Description
AN	Standard nameplate, radial ports
BN	Standard label, axial ports

I Name Plate

Code	Description
NNN	No special features, standard black paint

Mounting Flanges

SAE-A 2-bolt flange (AA)

Dimensions mm [in]

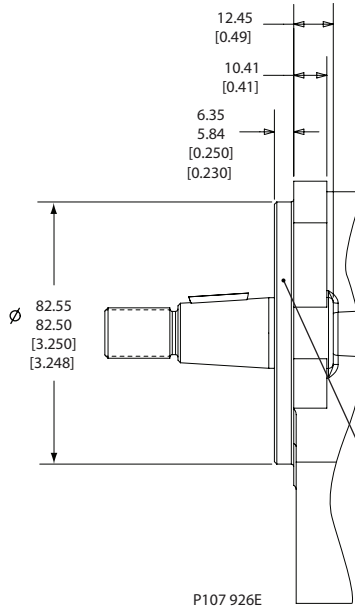
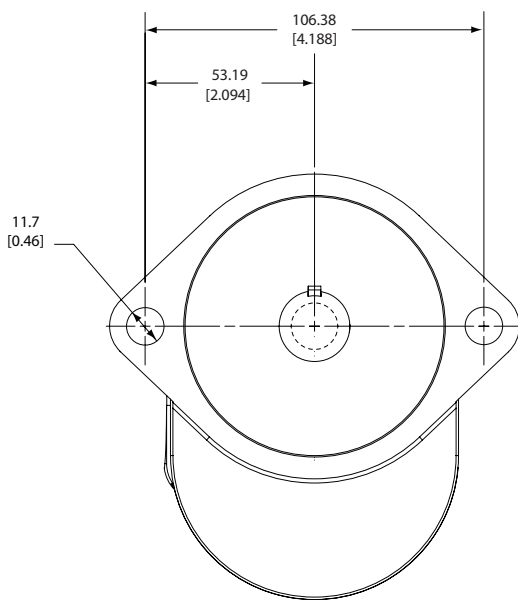

P107 926E

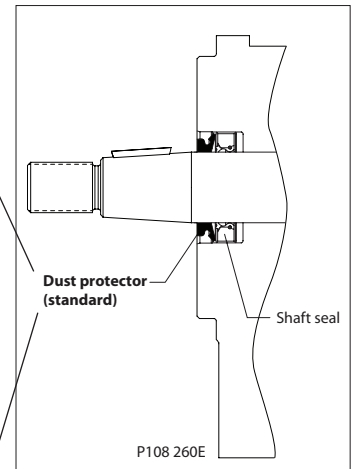

SAE-B 2-bolt flange (BB)

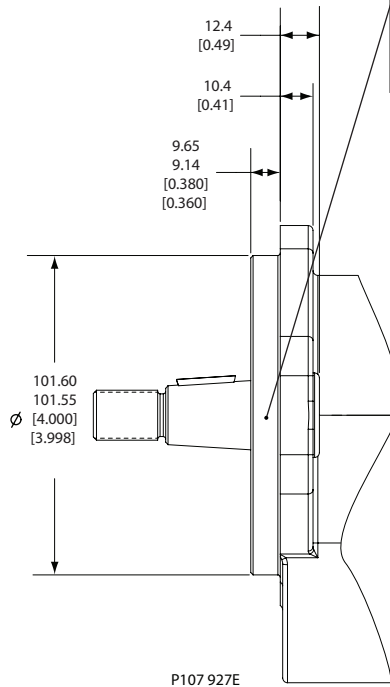
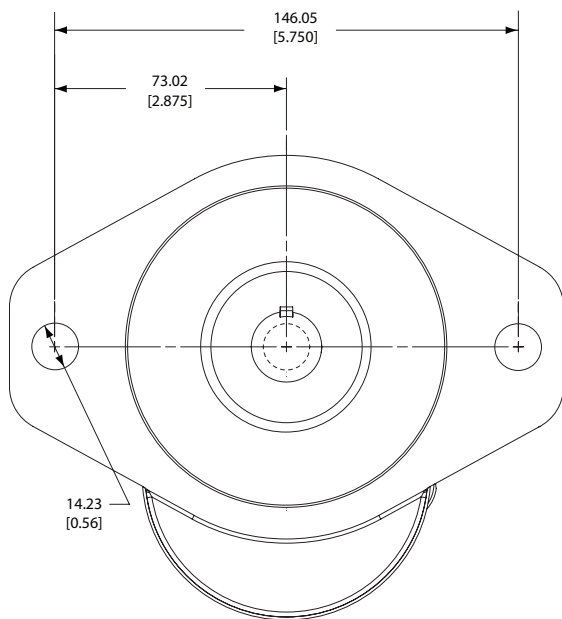

P107 927E

Shaft Options

SM shaft option

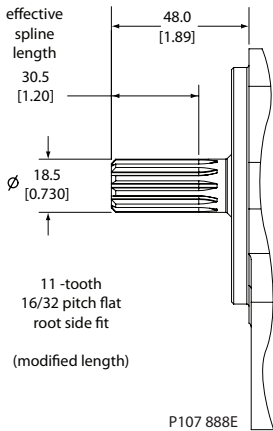

PB shaft option

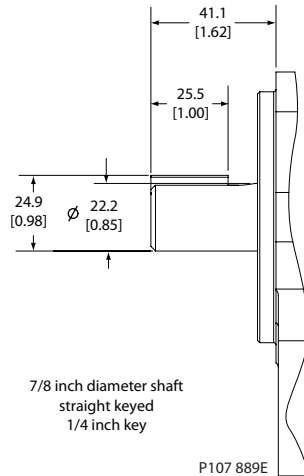

TY shaft option

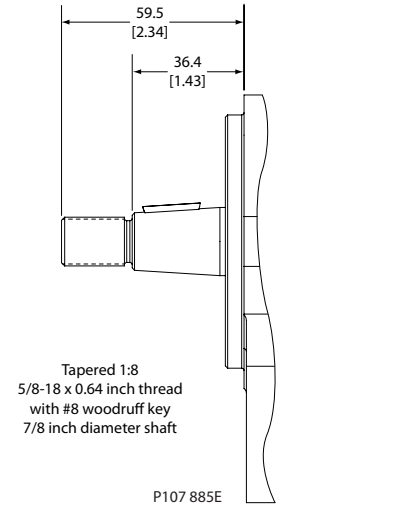

TK shaft option

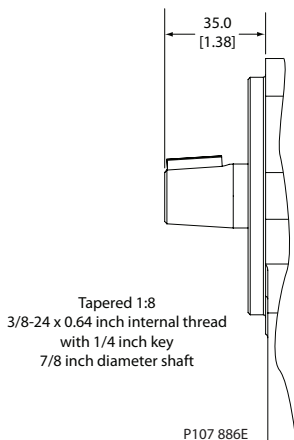

SH shaft option

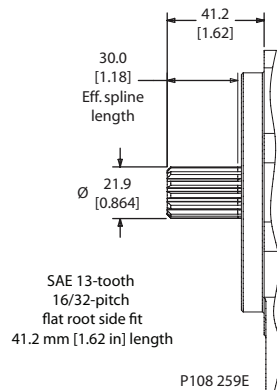

PW shaft option

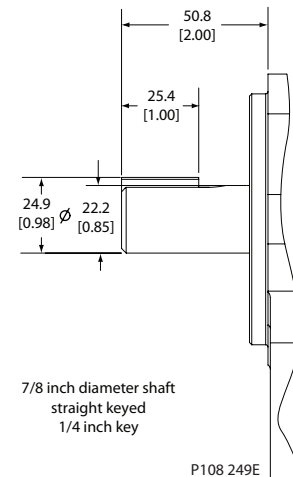

Shaft Torque Limits

Code	Type	Diameter mm [in]	Length mm [in]	Description	Allowable shaft torque N·m [lbf·in]
SM	Spline	19.1 [0.75]	38.1 [1.50]	11 tooth, 48 mm [1.89 in] extension, (modified length) 30 mm [1.20 in] effective spline	176.3 [1560]
PB	Straight key	22.2 [0.875]	41.2 [1.62]	SAE 22 mm [7/8 in] \varnothing x 41 mm [1.62 in] Extension, 1/4 in key, with key	248.6 [2200]
TY	Tapered	22.2 [0.875]	49.6 [1.95]	SAE 1:8 taper, 22mm [7/8 in] \varnothing x 59mm [2.34 in] Extension, 5/8-18 x 21 mm [.81 in] external thread with #8 Woodruff key	225.9 [2000]
TK	Tapered	22.2 [0.875]	49.3 [1.94]	1:8 taper, 22mm [7/8 in] \varnothing x 35 mm [1.38 in] Extension, 3/8-24 x 19 mm [.75 in] Internal thread	225.9 [2000]
SH	Spline	21.9 [0.864]	41.2 [1.62]	13 tooth, 41 mm [1.62 in] length	248.6 [2200]
PW	Straight key	22.2 [0.875]	50.8 [2.00]	SAE 22 mm [7/8 in] \varnothing x 51 mm [2 in] Extension, 1/4 in key, with key	248.6 [2200]

Port Options

SAE O-Ring Boss

Code		SAE O-ring boss ports - No valves		
Radial	Axial	Inlet	Outlet	Drain port
N105	N505	3/4-16 SAE	3/4-16 SAE	Radial 9/16-18 SAE (on idler side)
N106	N506	3/4-16 SAE	3/4-16 SAE	Radial 9/16-18 SAE (on drive side)
N107	N507	7/8-14 SAE	7/8-14 SAE	Radial 9/16-18 SAE (on idler side)
N108	N508	7/8-14 SAE	7/8-14 SAE	Radial 9/16-18 SAE (on drive side)
N109	N509	1 1/16-12 SAE	1 1/16-12 SAE	Radial 9/16-18 SAE (on idler side)
N110	N510	1 1/16-12 SAE	1 1/16-12 SAE	Radial 9/16-18 SAE (on drive side)
N111	N/A	1 5/16-12 SAE	1 5/16-12 SAE	Radial 9/16-18 SAE (on idler side)
N112	N/A	1 5/16-12 SAE	1 5/16-12 SAE	Radial 9/16-18 SAE (on drive side)

Port locations (SAE O-ring port shown)

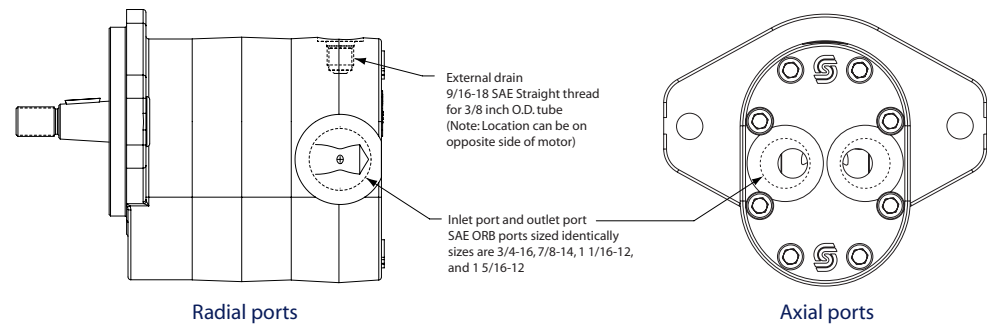

SAE Split Flange Ports

Code		SAE Split flange ports - No valves		
Radial		Inlet	Outlet	Drain port
N330		1 inch Split flange	1 inch Split flange	Radial 9/16-18 SAE (on idler side)
N331		1 inch Split flange	1 inch Split flange	Radial 9/16-18 SAE (on drive side)
N332		1-1/4 Split flange	1-1/4 Split flange	Radial 9/16-18 SAE (on idler side)
N333		1-1/4 Split flange	1-1/4 Split flange	Radial 9/16-18 SAE (on drive side)

Split flange ports

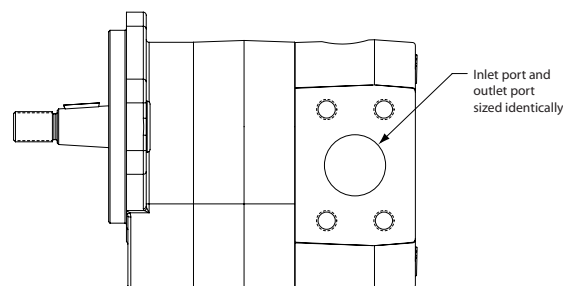

D Series Gear Motors Including Fan Drive Technical Information Options

Selecting Port Options

Use the following tables for selecting port options. Recommendations assume maximum rated speed. Applications running at lower speeds may use smaller port sizes. Contact your TurollaOCG representative.

Recommended part size by displacement

Displacement code	Recommended port size
14	1-1/16
17	1 - 1/16
19	1 - 5/16
21	1 - 5/16
23	1 - 5/16
25	1 - 5/16
29	1 - 5/16
32	1 - 5/16
36	1 - 5/16
38	1 - 5/16
41	1 - 5/16
45	1 inch split flange

Maximum flow by port size

Port size	Maximum flow l/min [US gal/min]
3/4 -16 SAE ORB	26 [7]
7/8-14 SAE ORB	41 [11]
1 1/16-12 SAE ORB	68 [18]
1 5/16-12 SAE ORB	132 [35]
1 inch Split flange	216 [57]
1 1/4 Split flange	288 [76]

D Series Gear Motors Including Fan Drive Technical Information Options

Integrated Reversing Motor with Proportional Relief and Shock/Anti-cavitation Valves

The D Series Motor can be configured to include an integrated reversing option for high performance fan drive systems requiring variable speed and reversal of fan direction to purge coolers and radiators.

Features and Benefits

- Solenoid reversing valve directs flow to either side of the motor to reverse fan rotation. The valve uses an open transition spool to reduce the likelihood of pressure spikes during sudden reversals and is available in two flow ranges to minimize losses.
- Integrated proportional pressure control to modulate fan speed by modulating pressure across the fan motor. The valve is available in two flow ranges and is normally closed to ensure full fan speed in case of loss of electrical signal.
- Dual shock valves limit pressure spikes in both forward and reverse rotation and eliminates damage to the system during sudden fan reversals
- Dual anti-cavitation check valves bypass motor flow during fan deceleration.
- The motor is PLUS+1TM compliant allowing the user to take advantage of automatic cleaning sequences available on TurollaOCG microcontrollers
- Valves are qualified to 276 bar (4000 psi) and are contained in a steel body to ensure maximum performance and long life at elevated temperatures and pressures.
- Deutsch connectors, Viton[®] seals and shaft dust protector are standard for operation in severe environments
- Integrated valve design provides short length and high power density in a compact package while minimizing installation costs.

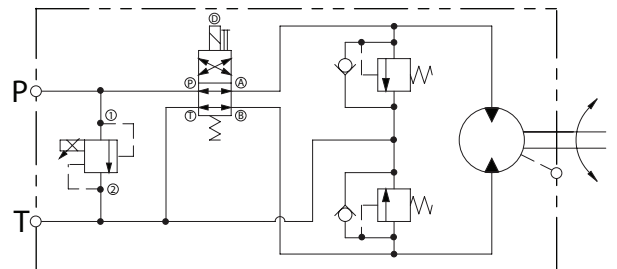

P108 250E

Technical Data

The directional control valve uses an internal spring to bias spool position and direct flow to the motor. As a result, the preferred motor rotation must be specified in the model code. A right hand motor would be biased for clockwise rotation with counter-clockwise reversing, while a left hand motor would be biased for counter-clockwise rotation with clockwise reversing.

The reversing valve function is available in two flow ratings. The D05 directional valve is standard with the high flow proportional valve, while the D03 directional valve is standard with the low flow proportional valve. Use the P-T pressure drop curves to minimize pressure drop at maximum flow conditions.

D Series Gear Motors Including Fan Drive Technical Information Options

Integrated Reversing with Proportional Relief and Shock/Anti- cavitation Valves (continued)

Integrated Reversing Function

Select the size and voltage of the reversing valve option using the codes and P-T pressure drop curves below. The pressure settings and performance curves for the proportional relief valve can be found on the following pages.

Code	Description
A1	D03 Directional valve with P1 (low flow) style proportional relief valve, 12VDC
A2	D03 Directional valve with P3 (low flow) style proportional relief valve, 24VDC
B1	D05 Directional valve with P2 (high flow) style proportional relief valve, 12VDC
B2	D05 Directional valve with P4 (low flow) style proportional relief valve, 24VDC

Pressure loss measured with Mobile DTE 24 at 105° F

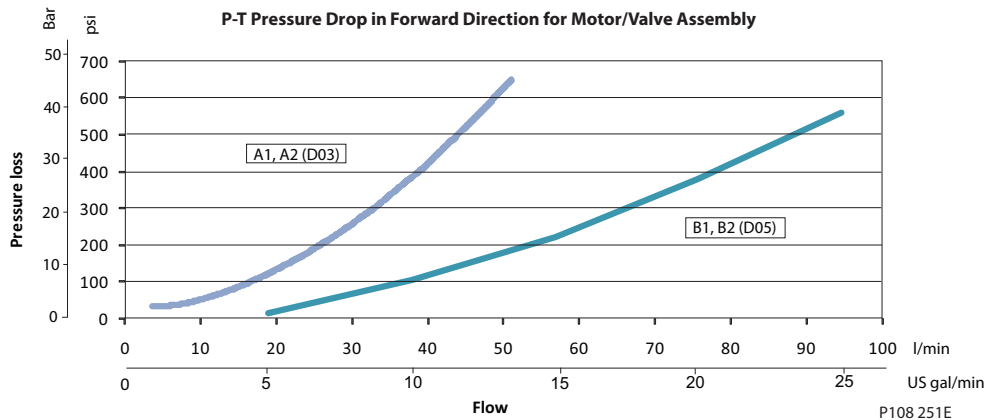

Includes pressure drop across D03/D05 in default position as well as losses across unloaded gear motor

D Series Gear Motors Including Fan Drive

Technical Information

Options

Standard Relief Valve

The fixed-setting pressure relief valve limits maximum fan speed and protects the motor from over-pressurization.

Mount the motor so the relief valve is below the reservoir oil level. Keep the relief valve in a horizontal position. Be sure to bleed the system to remove entrained air.

Relief valve codes

Code	Description
F	Relief valve internally drained - applications with 95 l/min [26 US gal/min] or less flow
G	Relief valve internally drained - applications with 96-190 l/min [26-50 US gal/min] flow

Any modification to the valve to change the factory setting will void product warranty.

The fixed-setting relief valve can only be used to limit fan speed in one rotational direction. As a result, the preferred motor rotation must be specified in the model code - DEML or DEMR.

Schematic - Motor with standard relief valve with optional anti-cavitation valve

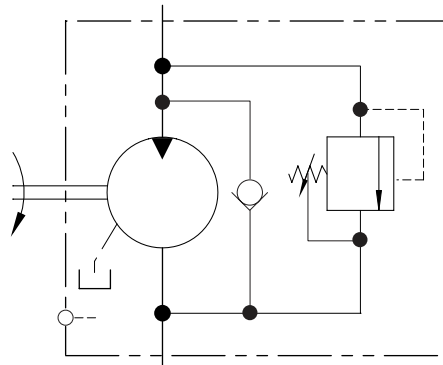

Standard relief valve

Anti-cavitation check valve

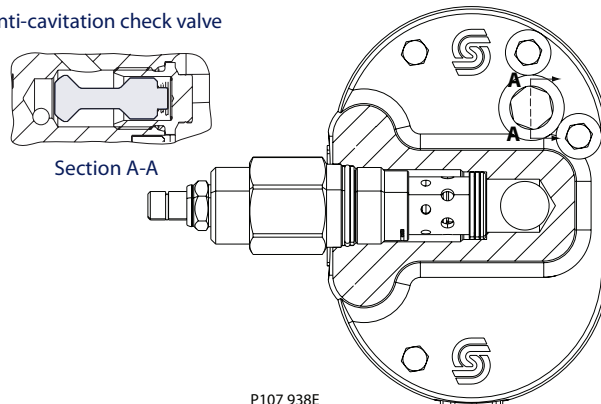

D Series Gear Motors Including Fan Drive

Technical Information

Options

Standard Relief Valve (continued)

Valve option	Pressure setting bar [psi]
276	276 [4000]
241	241 [3500]
207	207 [3000]
172	172 [2500]
138	138 [2000]

Valve Settings

Relief pressure vs flow at $T_{oil}=51.7^{\circ}\text{C}$ [125°F], viscosity = 30 mm²/sec (cSt) [121 SUS] set at 19 l/min [5 US gal/min]

F Valve settings

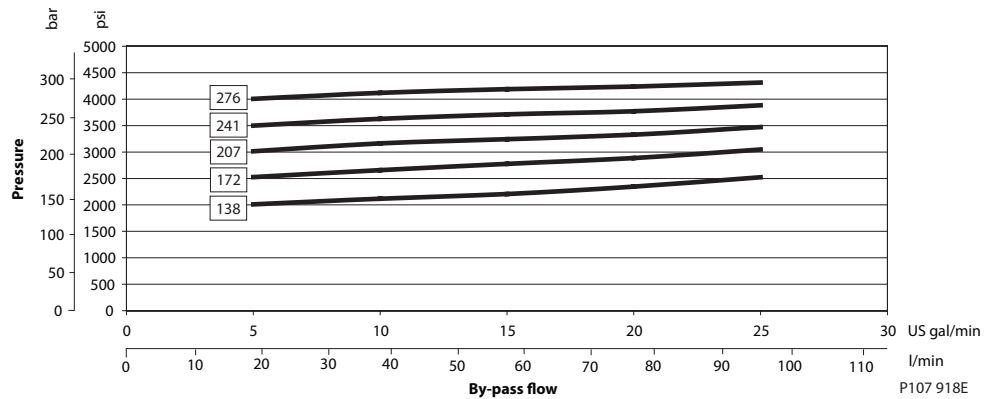

G Valve settings

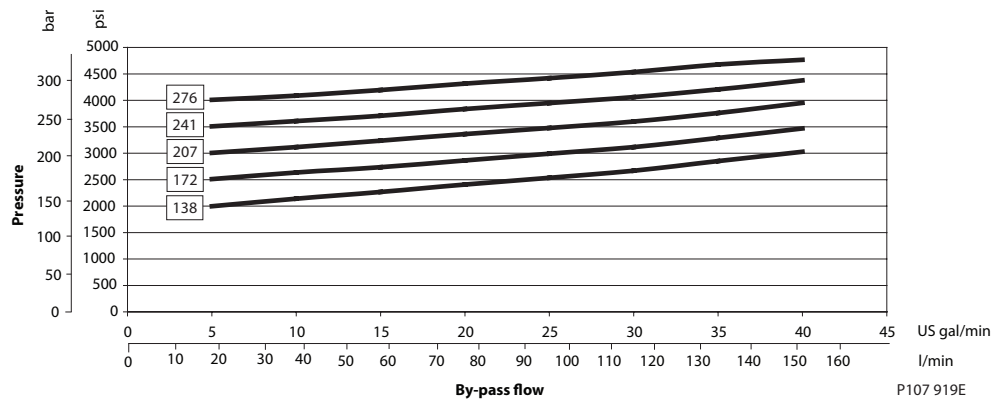

D Series Gear Motors Including Fan Drive

Technical Information

Options

Anti-cavitation Check Valve

D motors are available with an optional anti-cavitation check valve. The valve is integrated into the rear cover. The anti-cavitation check valve protects the motor from cavitation in overrunning conditions.

Standard rear cover with anti-cavitation valve

Anti-cavitation check valve

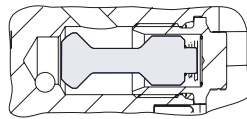

Section A-A

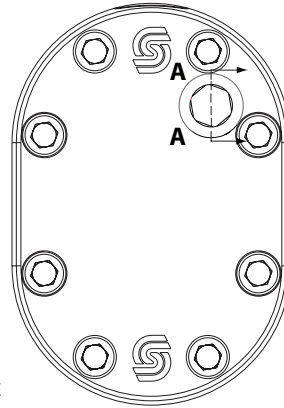

P107 956E

Schematic - Motor with anti-cavitation check valve

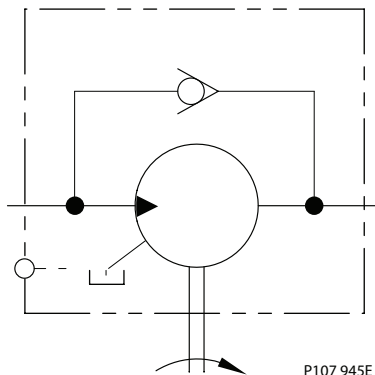

P107 945E

D Series Gear Motors Including Fan Drive Technical Information Options

Proportional Relief Valve with Anti-cavitation Valve

The D Series motor may be equipped with a normally closed proportional relief valve, which modulates the fan speed for on demand cooling in fan drive applications. This valve can also trim maximum fan speed at a pre-set pressure.

Mount the motor so the relief valve is below the reservoir oil level. Keep the relief valve in a horizontal position. Be sure to bleed the system to remove entrained air.

Relief valve cutaway

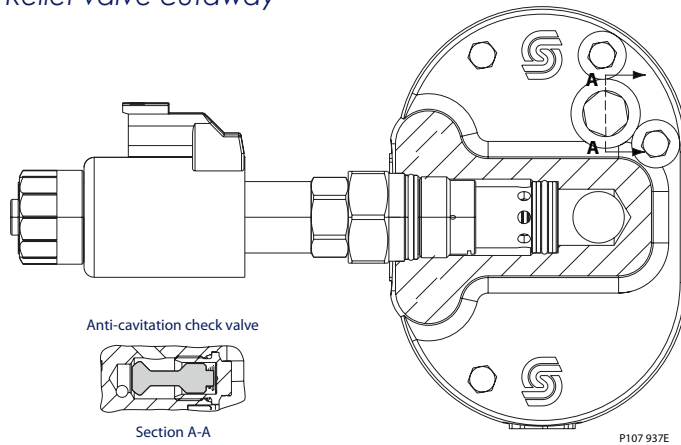

Technical data

Capacity	95 l/min [25 US gal/min] or 96-190 l/min [25-50 US gal/min]	
Electrical connector	Deutsch ® DT-04-2P (protection rate IP 69K DIN 40050)	
Electrical supply	0 -1.1 A at 12 Vdc with	Coil resistance of 6.4 Ohms at 20° C [68° F]
		Minimum voltage 10.8 Vdc
		Maximum voltage 13.2 Vdc
	0 -0.55 A at 24 Vdc with	Coil resistance of 26.2 Ohms at 20° C [68° F]
		Minimum voltage 21.6 Vdc
		Maximum voltage 26.4 Vdc
PWM frequency	100 - 250 Hz	

The proportional relief valve can only be used to modulate fan speed in one rotational direction. As a result, the preferred motor rotation must be specified in the model code - DEML or DEMR.

Motor with proportional relief valve and anti-cavitation check valve

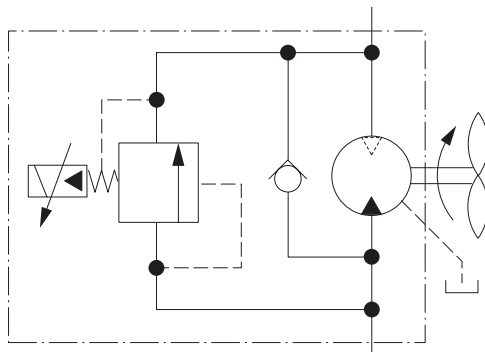

Proportional Relief Valve (continued)

Valve Settings

Code	Description
P1	12 Vdc Proportional relief valve internally drained, low flow
P2	12 Vdc Proportional relief valve internally drained, high flow
P3	24 Vdc Proportional relief valve internally drained, low flow
P4	24 Vdc Proportional relief valve internally drained, high flow

Select proportional relief valve setting using the pressure vs. bypass flow graphs. Any modification to the valve to change the factory setting will void product warranty.

Valve option	Pressure setting bar [psi]
AF	276 [4000]
AD	241 [3500]
AC	207 [3000]
AB	172 [2500]
AA	138 [2000]

P1 and P3 valve settings, (low flow)

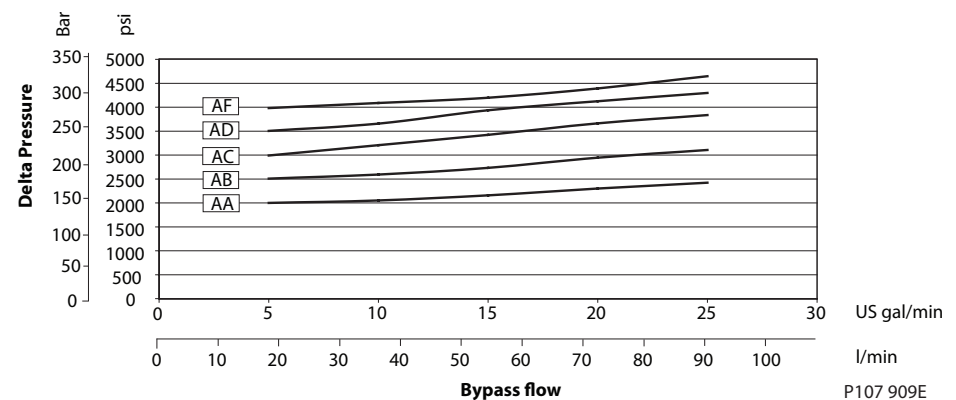

Valve option	Pressure setting bar [psi]
BF	276 [4000]
BD	241 [3500]
BC	207 [3000]
BB	172 [2500]
BA	138 [2000]

P2 and P4 valve settings, (high flow)

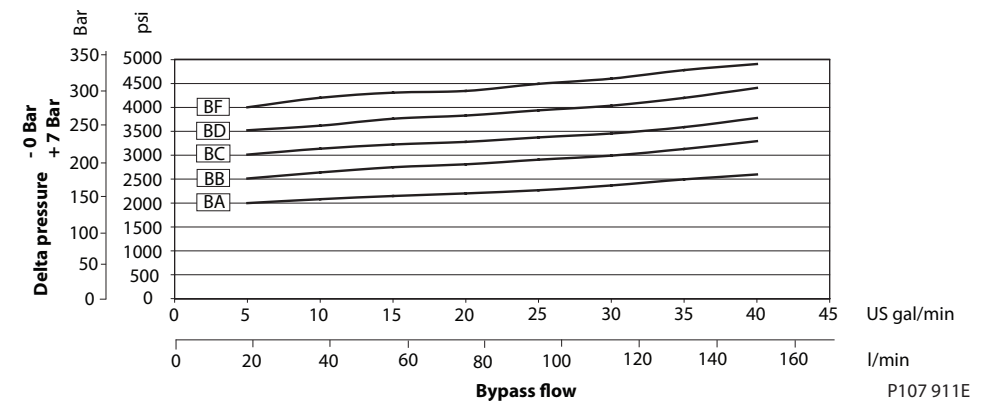

D Series Gear Motors Including Fan Drive

Technical Information

Options

Proportional Relief Valve (continued)

Performance Graphs

Relief pressure vs flow at $T_{oil}=51.7^{\circ}\text{C}$ [125°F], viscosity = 30 mm²/sec (cSt) [121 SUS] set at 19 l/min [5 US gal/min] and zero current

Pressure drop with coil energized, valve only

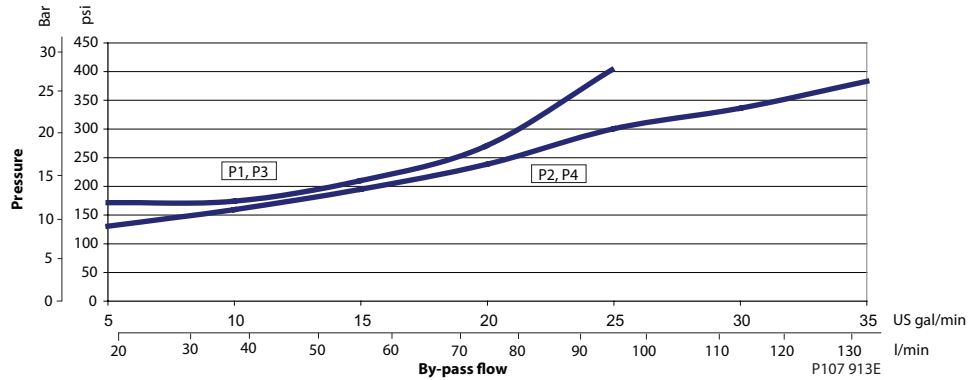

Valve Settings

Code	Description
P1	12 Vdc Proportional relief valve internally drained - with 95 l/min [25 US gal/min] or less flow
P2	12 Vdc Proportional relief valve internally drained - with 96-190 l/min [26-50 US gal/min] flow
P3	24 Vdc Proportional relief valve internally drained - with 95 l/min [25 US gal/min] or less flow
P4	24 Vdc Proportional relief valve internally drained - with 96-190 l/min [26-50 US gal/min] flow

Any modification to the valve to change the factory setting will void product warranty.

D Series Gear Motors Including Fan Drive

Technical Information

Options

Proportional Relief Valve (continued)

Relief pressure vs flow at $T_{oil}=51.7^{\circ}\text{C}$ [125°F], viscosity = 30 mm²/sec (cSt) [121 SUS] set at 19 l/min [5 US gal/min] and zero current

P1, Relief pressure vs. current

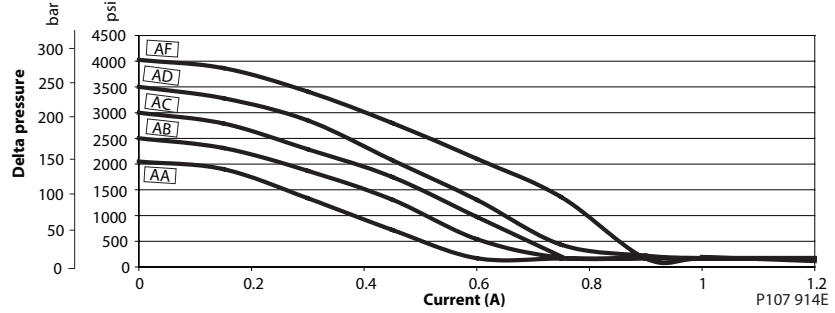

P2, Relief pressure vs. current

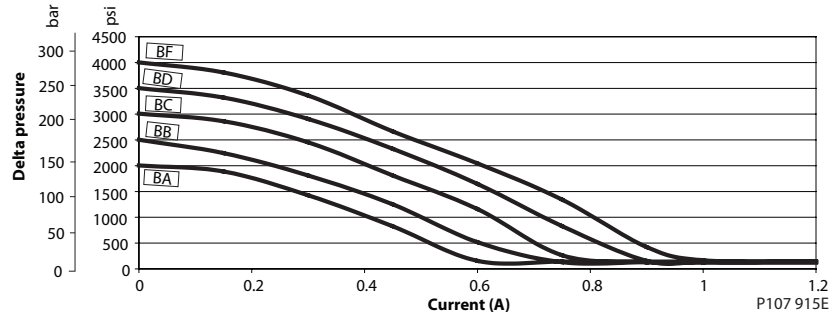

P3, Relief pressure vs. current

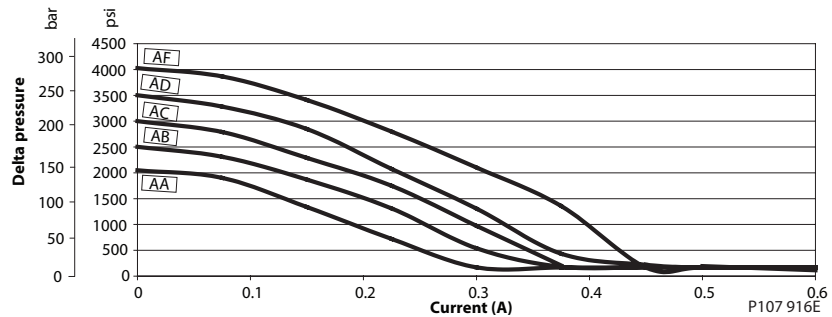

P4, Relief pressure vs. current

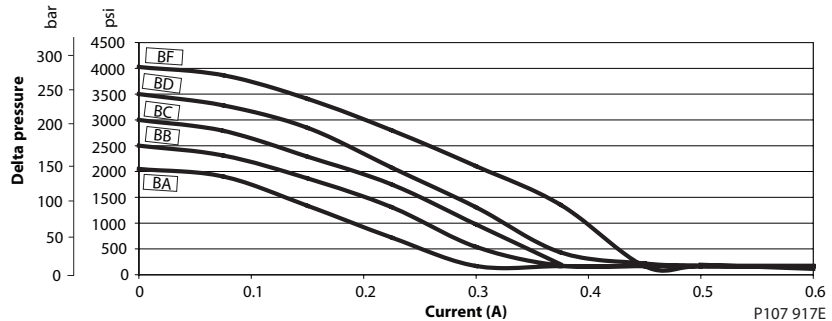

D Series Gear Motors Including Fan Drive

Technical Information

Dimension Drawings

Fan Drive Motor

Fan Drive Motor Example:

Fan drive motor:

A Right hand rotation, **B** 17 cm³, 1:8 taper shaft, **C** SAE A two bolt mounting, **D** 7/8-14 ports, idler side drain, **E** P1 style proportional relief valve at 172 bar, **F** anti-cavitation valve.

D motor dimensions; SAE-B two bolt fan drive motor shown

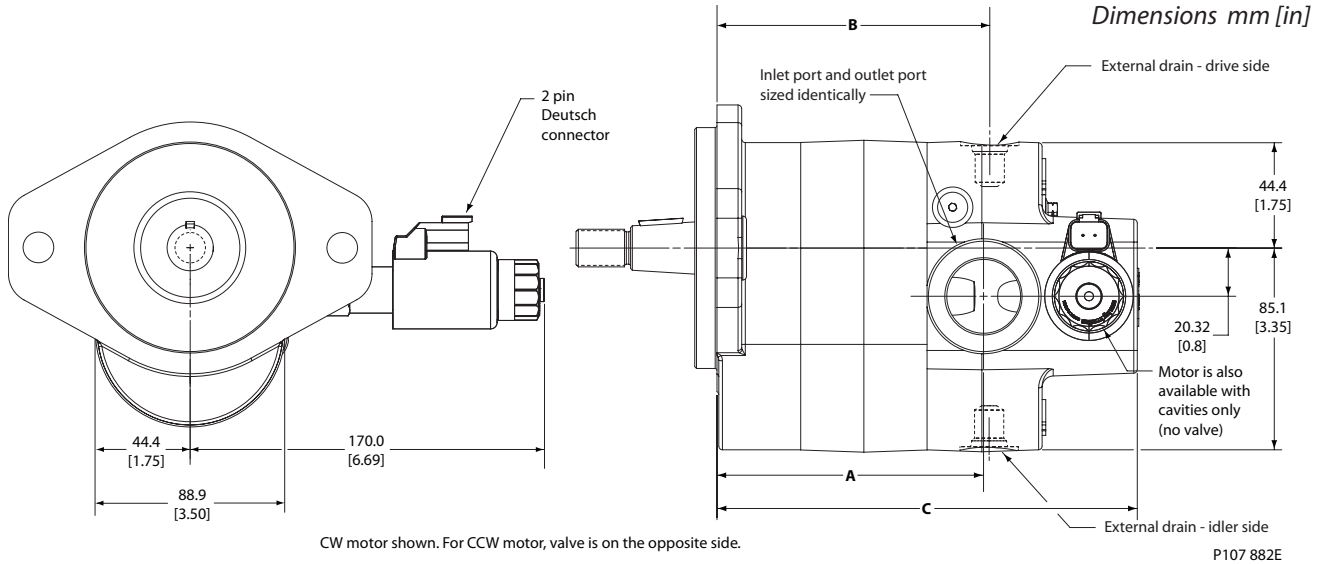

Dimensions (maximum)

Dimension	Units	14	17	19	21	23	25	29	32	36	38	41	45
A	mm	86.2	88.9	90.9	92.5	94.2	97.3	100.8	103.6	107.7	109.7	112.8	117.1
	in	3.40	3.50	3.58	3.64	3.71	3.83	3.97	4.08	4.24	4.32	4.44	4.61
B	mm	89.0	91.7	93.8	95.3	97.0	100.1	103.6	106.4	110.7	112.5	115.6	119.9
	in	3.51	3.61	3.69	3.75	3.82	3.94	4.08	4.19	4.36	4.43	4.55	4.72
C	mm	151.8	154.4	156.5	158.0	160.0	162.8	166.4	169.2	173.5	175.5	178.6	182.6
	in	5.89	6.08	6.18	6.22	6.30	6.41	6.55	6.66	6.83	6.91	7.03	7.19

D Series Gear Motors Including Fan Drive

Technical Information

Dimension Drawings

Standard Motor

Standard Motor Example:

A Right hand rotation, **B** 17 cm³, 1:8 taper shaft, **C** SAE A two bolt mounting, **D** 7/8-14 ports, idler side drain, **E** no relief valve.

Standard D motor dimensions, SAE-B two bolt motor shown

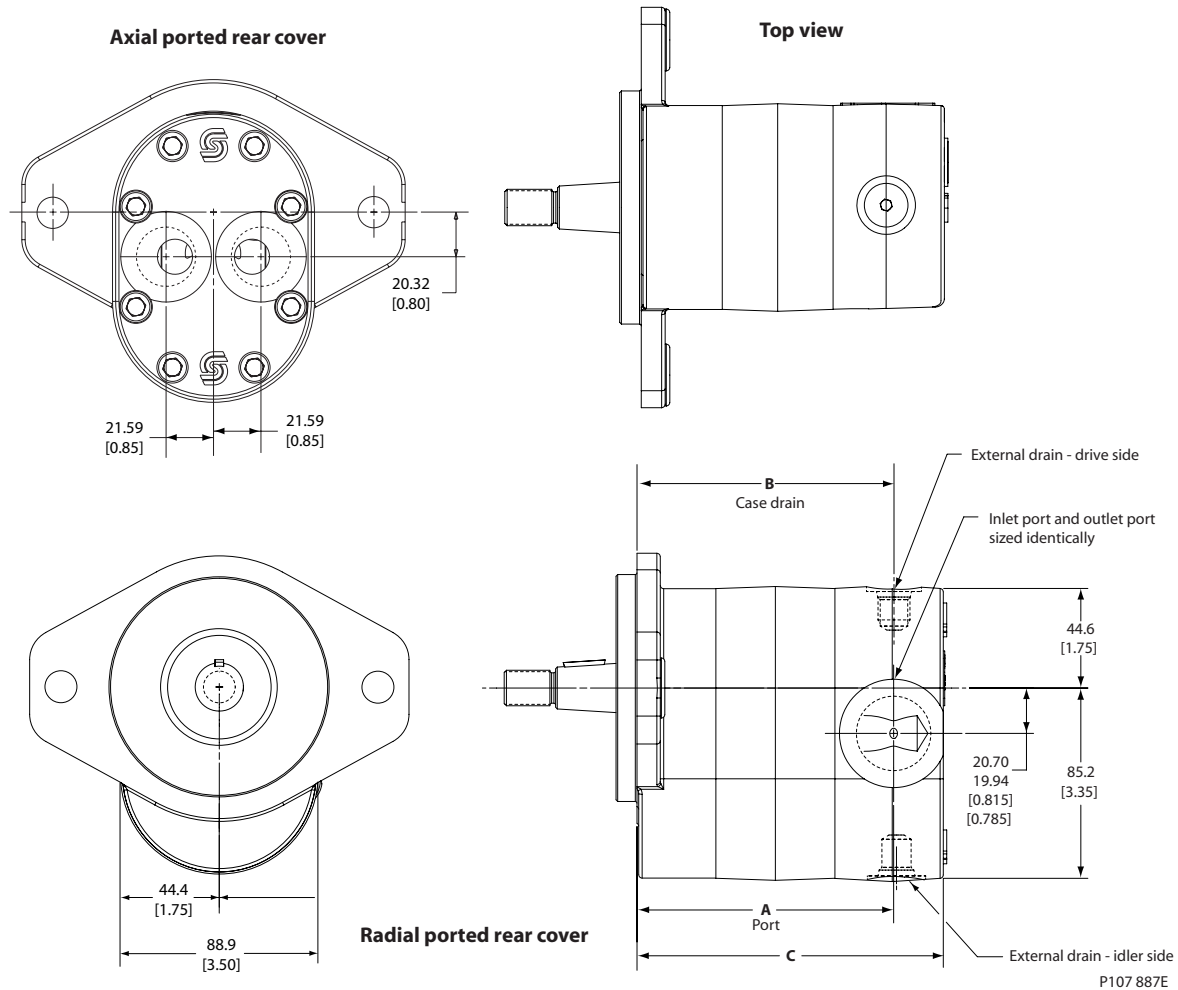

Dimensions (maximum)

Dimension	Units	14	17	19	21	23	25	29	32	36	38	41	45
A	mm	88.5	91.2	93.2	94.7	96.8	99.6	103.1	105.1	110.2	112.3	115.3	119.4
	in	3.49	3.59	3.67	3.73	3.81	3.92	4.06	4.17	4.34	4.42	4.54	4.70
B	mm	89.0	91.7	93.8	95.3	97.0	100.1	103.6	106.4	110.7	112.5	115.6	119.9
	in	3.51	3.61	3.69	3.75	3.82	3.94	4.08	4.19	4.36	4.43	4.55	4.72
C	mm	111.1	113.8	115.8	117.4	119.4	122.2	125.7	128.5	132.8	134.9	137.9	139.5
	in	4.38	4.48	4.56	4.62	4.70	4.81	4.95	5.06	5.23	5.31	5.43	5.49

Standard Motor with Split Flange Ports

Standard Motor with Split Flange Ports Example: **A** Right hand rotation, **B** 17 cm³, 1:8 taper shaft, **C** SAE A two bolt mounting, **D** Split flange ports, drive side drain, **E** No valve.

Standard D motor dimensions, SAE-B two bolt motor shown with split flange ports

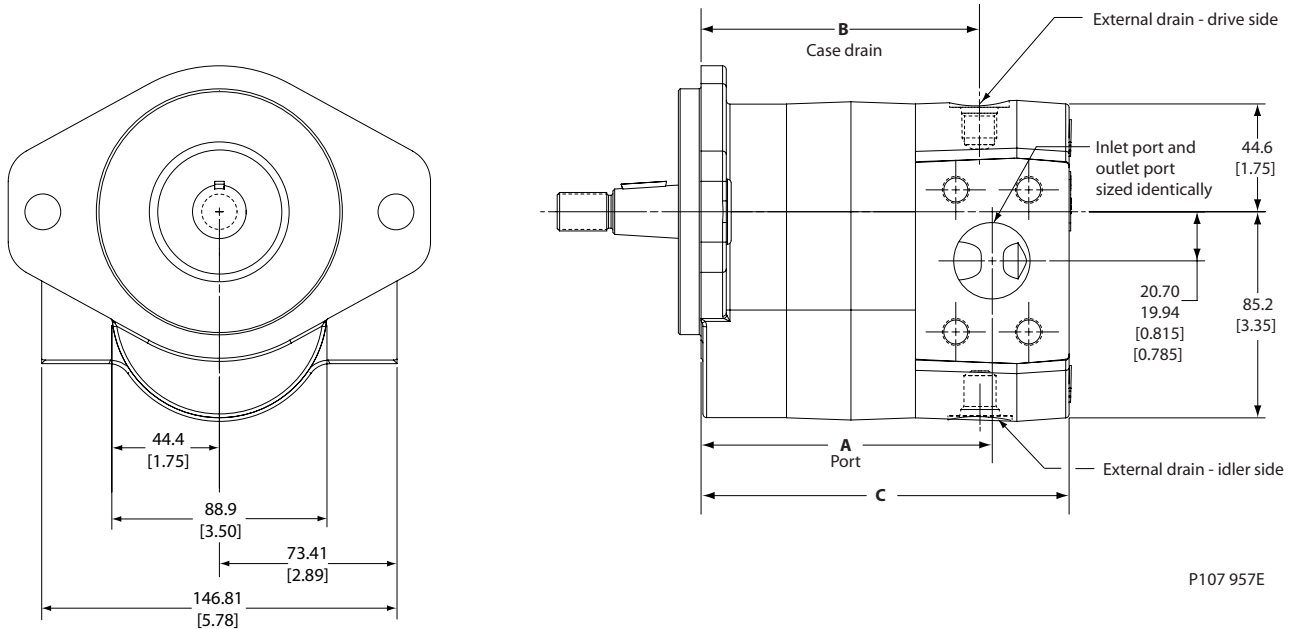

P107 957E

Dimensions (maximum)

Dimension	Units	14	17	19	21	23	25	29	32	36	38	41	45
A	mm	94.1	96.8	98.8	100.3	102.1	105.2	108.7	111.5	115.8	117.6	120.6	125.0
	in	3.71	3.81	3.89	3.95	4.02	4.14	4.28	4.39	4.56	4.63	4.75	4.92
B	mm	89.0	91.7	93.8	95.3	97.0	100.1	103.6	106.4	110.7	112.5	115.6	119.9
	in	3.50	3.61	3.69	3.75	3.82	3.94	4.08	4.19	4.36	4.43	4.55	4.72
C	mm	126.1	128.8	130.8	132.3	134.4	137.2	140.7	143.5	147.8	149.9	152.9	157.0
	in	4.97	5.07	5.15	5.21	5.29	5.40	5.54	5.65	5.82	5.90	6.02	6.18

Integrated Reversing Motor with Proportional Relief and Shock/Anti-cavitation Valves

Reversing Fan Drive Motor with D03 Directional Valve, Clockwise rotation

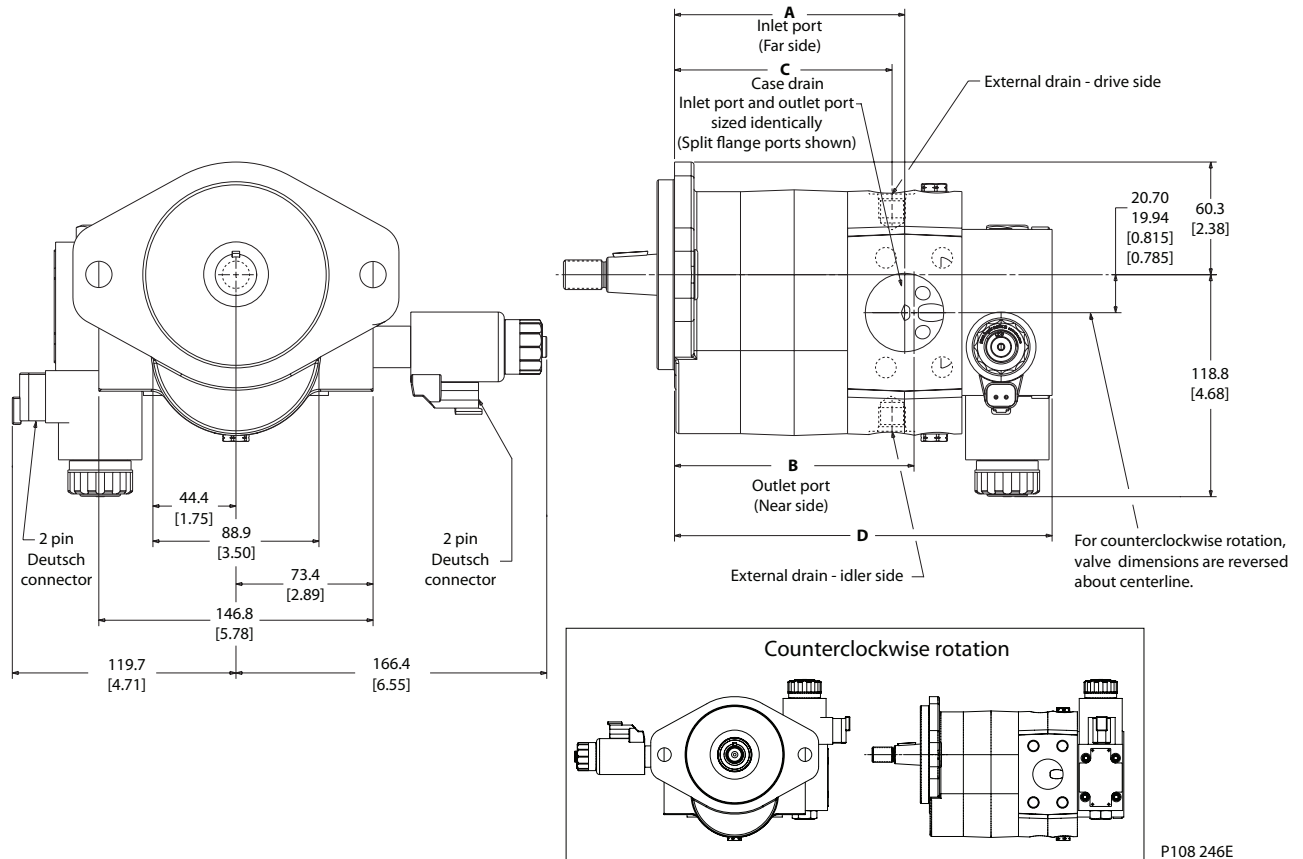

P108 246E

Dimensions (maximum)

Dimensions	Port	Units	14	17	19	21	23	25	29	32	36	38	41	45	
A	All	mm	92.4	95.0	97.1	98.6	100.4	103.4	107.0	109.8	114.0	116.0	119.0	123.2	
		in	3.64	3.74	3.82	3.88	3.95	4.07	4.21	4.32	4.49	4.57	4.69	4.85	
B	107 - 108	mm	100.6	103.3	105.3	106.9	108.7	111.7	115.3	118.0	122.3	124.3	127.3	131.5	
		in	3.96	4.07	4.15	4.21	4.28	4.40	4.54	4.65	4.82	4.89	5.01	5.18	
	109 - 110	mm	98.5	101.1	103.1	104.7	106.5	109.5	113.1	115.8	120.1	122.1	125.1	129.3	
		in	3.88	3.98	4.06	4.12	4.19	4.31	4.45	4.56	4.73	4.81	4.93	5.09	
	111 - 112	mm	95.1	97.7	99.8	101.3	103.1	106.1	109.7	112.5	116.8	118.7	121.7	125.9	
		in	3.74	3.85	3.93	3.99	4.06	4.18	4.32	4.43	4.60	4.67	4.79	4.96	
	330 - 331	mm	98.0	100.6	102.7	104.2	106.0	109.0	112.6	115.4	119.6	121.6	124.6	128.8	
		in	3.86	3.96	4.04	4.10	4.18	4.29	4.43	4.54	4.71	4.79	4.91	5.07	
	332 - 333	mm	97.4	100.0	102.1	103.6	105.4	108.4	112.0	114.8	119.0	121.0	124.0	128.2	
		in	3.83	3.94	4.02	4.08	4.15	4.27	4.41	4.52	4.69	4.76	4.88	5.05	
	C	All	mm	85.6	88.2	90.3	91.8	93.6	96.6	100.2	103.0	107.3	109.2	112.2	116.4
			in	3.37	3.47	3.55	3.61	3.69	3.80	3.95	4.05	4.22	4.30	4.42	4.58
D	All	mm	171.8	174.4	176.5	178.0	179.8	182.8	186.4	189.2	193.4	195.4	198.4	202.6	
		in	6.76	6.87	6.95	7.01	7.08	7.20	7.34	7.45	7.62	7.69	7.81	7.98	

Integrated Reversing Motor with Proportional Relief and Shock/Anti-cavitation Valves

Reversing Fan Drive Motor with D05 Directional Valve, Clockwise rotation

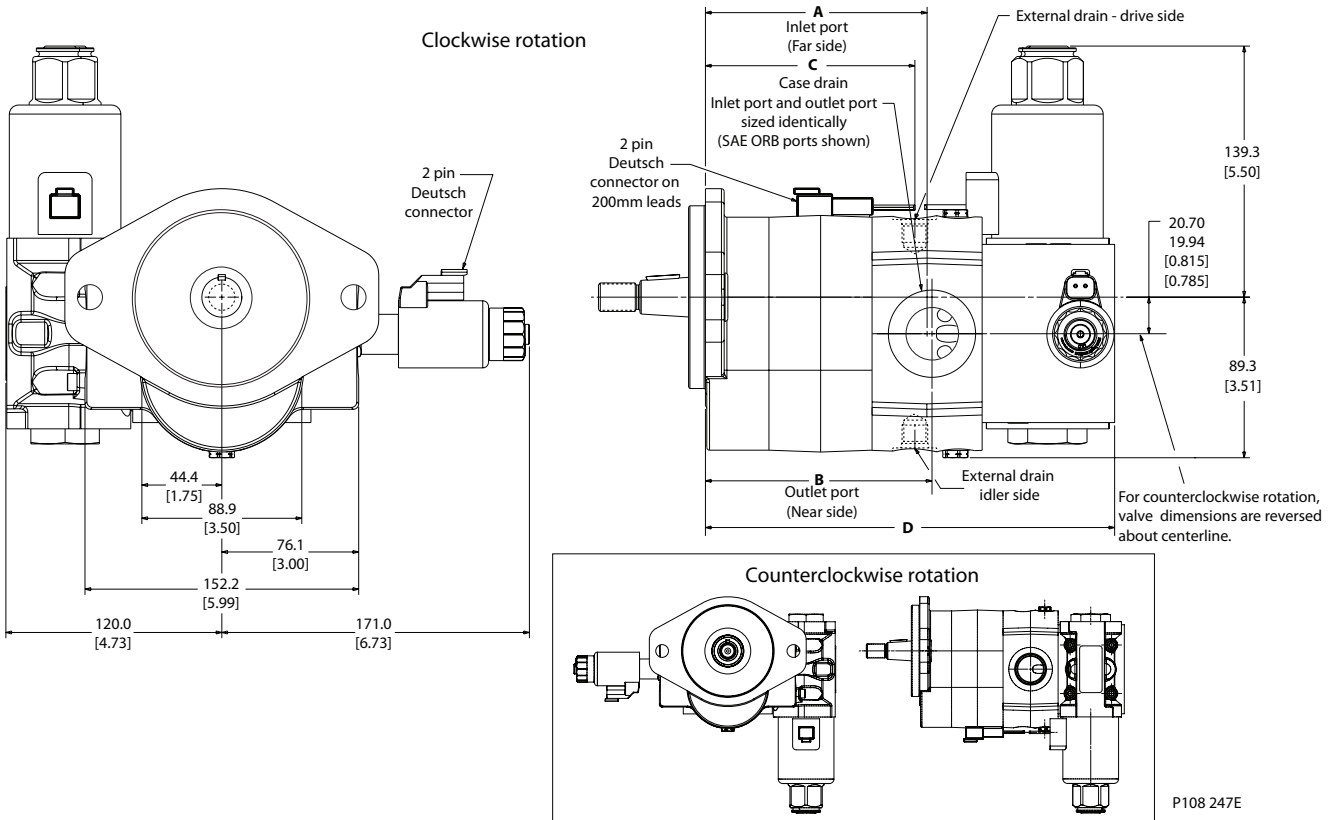

Dimensions (maximum)

Dimensions	Port	Units	14	17	19	21	23	25	29	32	36	38	41	45	
A	All	mm	92.4	95.0	97.1	98.6	100.4	103.4	107.0	109.8	114.0	116.0	119.0	123.2	
		in	3.64	3.74	3.82	3.88	3.95	4.07	4.21	4.32	4.49	4.57	4.69	4.85	
B	107 - 108	mm	100.6	103.3	105.3	106.9	108.7	111.7	115.3	118.0	122.3	124.3	127.3	131.5	
		in	3.96	4.07	4.15	4.21	4.28	4.40	4.54	4.65	4.82	4.89	5.01	5.18	
	109 - 110	mm	98.5	101.1	103.1	104.7	106.5	109.5	113.1	115.8	120.1	122.1	125.1	129.3	
		in	3.88	3.98	4.06	4.12	4.19	4.31	4.45	4.56	4.73	4.81	4.93	5.09	
	111 - 112	mm	95.1	97.7	99.8	101.3	103.1	106.1	109.7	112.5	116.8	118.7	121.7	125.9	
		in	3.74	3.85	3.93	3.99	4.06	4.18	4.32	4.43	4.60	4.67	4.79	4.96	
	330 - 331	mm	98.0	100.6	102.7	104.2	106.0	109.0	112.6	115.4	119.6	121.6	124.6	128.8	
		in	3.86	3.96	4.04	4.10	4.18	4.29	4.43	4.54	4.71	4.79	4.91	5.07	
	332 - 333	mm	97.4	100.0	102.1	103.6	105.4	108.4	112.0	114.8	119.0	121.0	124.0	128.2	
		in	3.83	3.94	4.02	4.08	4.15	4.27	4.41	4.52	4.69	4.76	4.88	5.05	
	C	All	mm	85.6	88.2	90.3	91.8	93.6	96.6	100.2	103.0	107.3	109.2	112.2	116.4
			in	3.37	3.47	3.55	3.61	3.69	3.80	3.95	4.05	4.22	4.30	4.42	4.58
D	All	mm	197.2	199.8	201.9	203.4	205.2	208.2	211.8	214.6	218.8	220.8	223.8	228.0	
		in	7.76	7.87	7.95	8.01	8.08	8.20	8.34	8.45	8.62	8.69	8.81	8.98	

D Series Gear Motors Including Fan Drive

Technical Information

Performance Data

Motor Performance Graphs

The graphs show typical inlet flow and output power for the D series motors at various working pressures as a function of speed. Data were taken using hydraulic fluid conforming to ISO VG46 at 50°C [120° F] with viscosity at 28 mm²/sec (cSt) [132 SUS].

14 cm³ [0.85 in³]

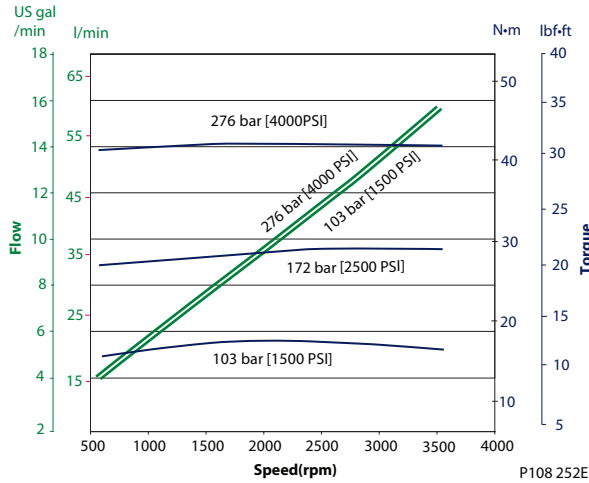

17 cm³ [1.04 in³]

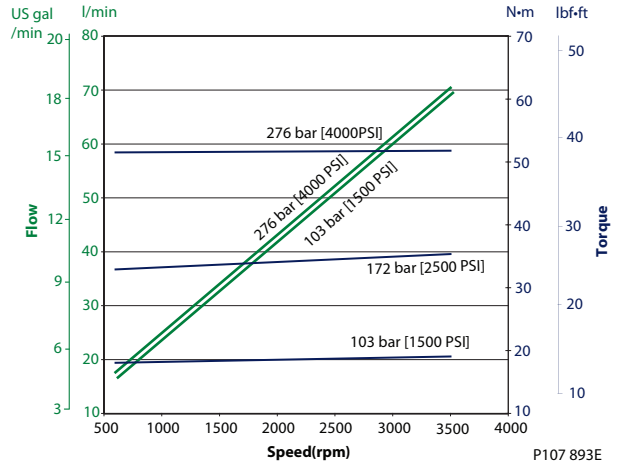

19 cm³ [1.16 in³]

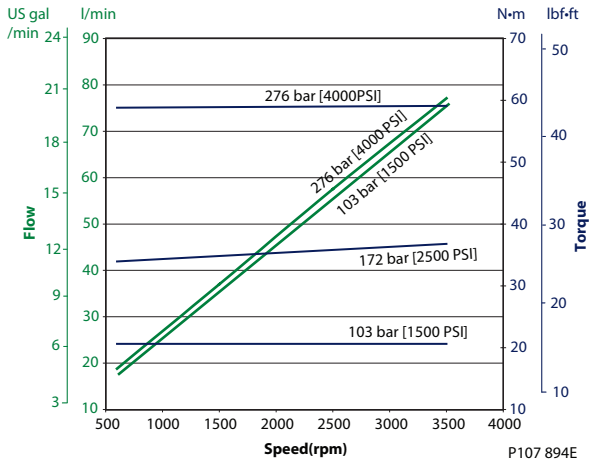

21 cm³ [1.25 in³]

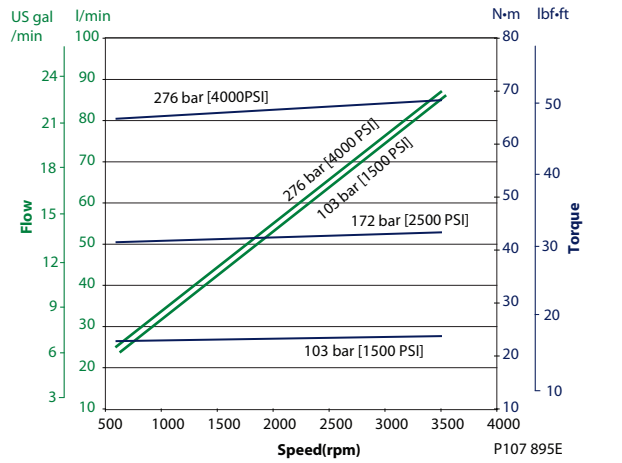

23 cm³ [1.37 in³]

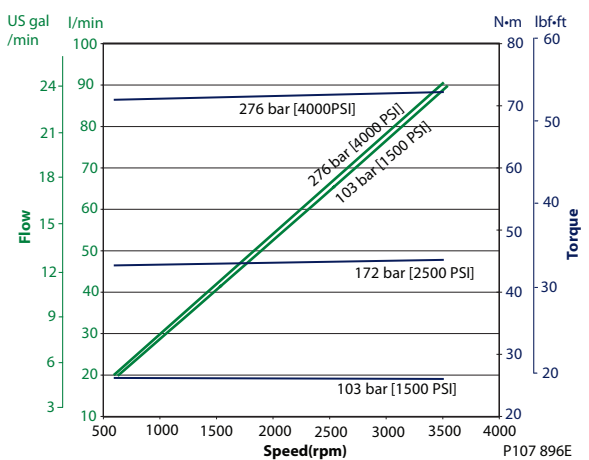

25 cm³ [1.55 in³]

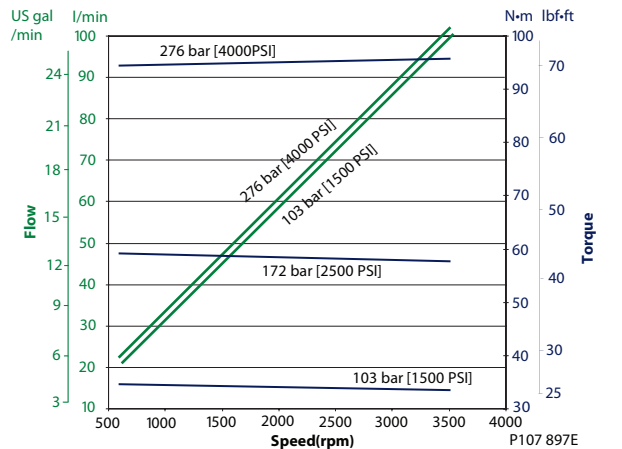

Motor Performance Graphs (continued)

29 cm³ [1.77 in³]

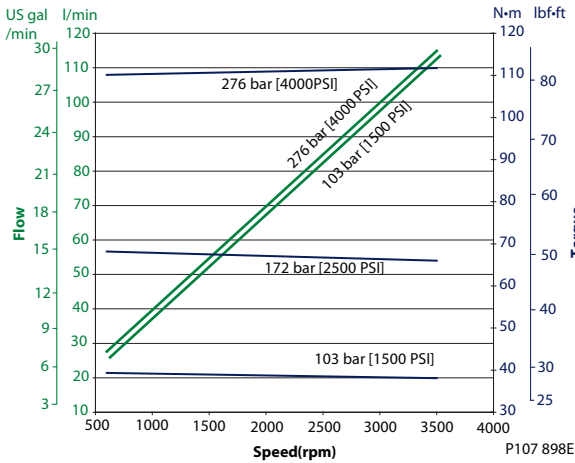

32 cm³ [1.94 in³]

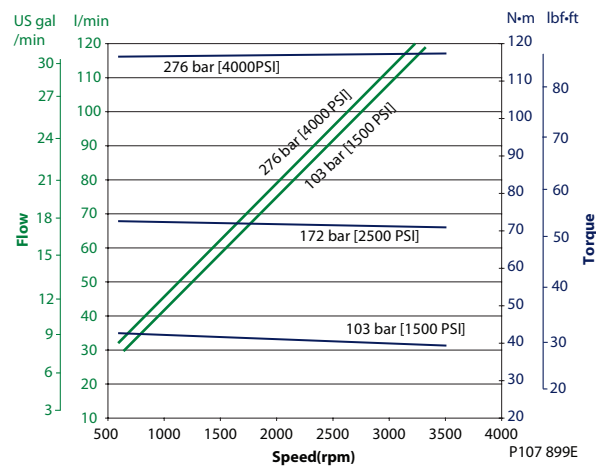

36 cm³ [2.20 in³]

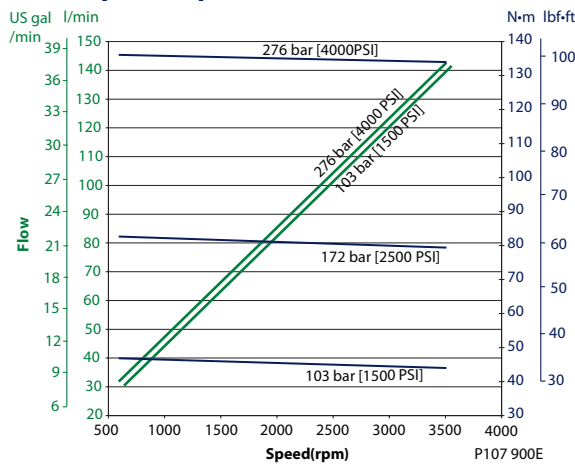

38 cm³ [2.32 in³]

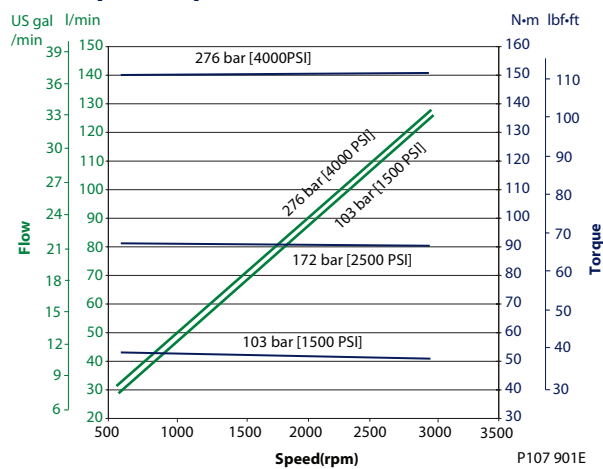

41 cm³ [2.50 in³]

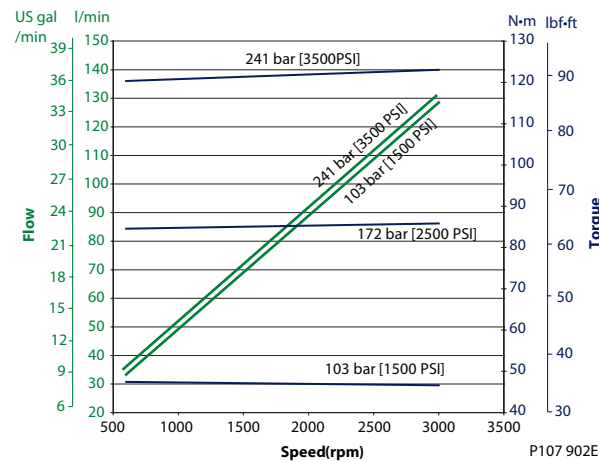

45 cm³ [2.75 in³]

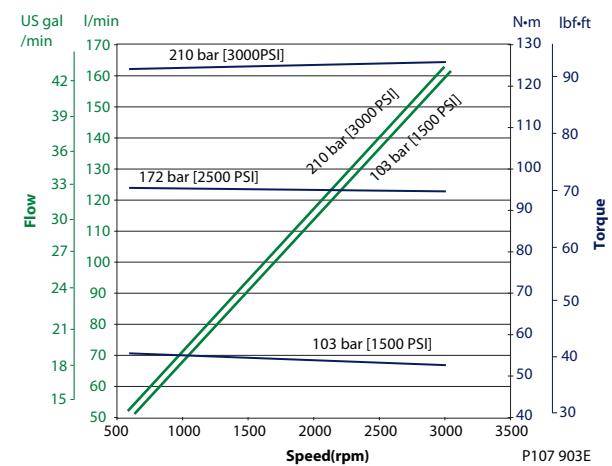

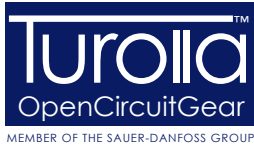

D Series Gear Motors Including Fan Drive

Technical Information

Reference Literature

TurollaOCG Fan Drive Related Literature

Literature reference - Software

Title	Type	Order number
SX Microcontroller Fan Drive Personality	Technical Information	11023458

Literature reference - Fan Drive Controls

Title	Type	Order number
Fan Drive Control	Technical Information	11005336
Fan Drive Control Assembly	Technical Information	11005337
Fan Drive Control Temperature Sensors	Technical Information	BLN-95-9063
PLUS+1 compliant Heavy-Duty Pressure Transmitter	Datasheet	520L0801
PLUS+1 compliant Heavy-Duty Pressure Transmitter - SAE Thread Version	Datasheet	11005336
PLUS+1 MC088 015-00000-Controller	Datasheet	11006645

Literature reference - Valves

Title	Type	Order number
Modulating and Reversing Fan Drive HICs	Datasheet	L1001666
Cartridge Valves	Technical Information	520L0588

Literature reference - Pumps and Motors

Title	Type	Order number
Series D Hydraulic Gear Pumps	Technical Information	L1022940
Group 2 Gear Pumps	Technical Information	L1016341
Group 3 Gear Pumps	Technical Information	L1016456
Group 1, 2 and 3 Gear Motors	Technical Information	L1016082
SGM2, SGM3 Fan Drive Gear Motors	Technical Information	L1016036
SGM2 Fan Drive Gear Motors	Datasheet	11029652
SGM3 Fan Drive Gear Motors	Datasheet	11056719
Series 45 Open Circuit Pumps	Technical Information	520L0519

Literature reference - Fluids

Title	Type	Order number
Hydraulic Fluids and Lubricants	Technical Information	L1021414

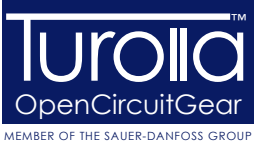

D Series Gear Motors Including Fan Drive
Technical Information
Notes

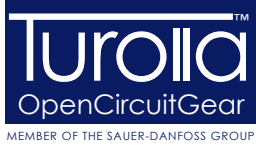

D Series Gear Motors Including Fan Drive Technical Information Notes

Our Products

Aluminum Gear Pumps

Aluminum Gear Motors

Cast Iron Gear Pumps

Cast Iron Gear Motors

Fan Drive Gear Motors Aluminum

Fan Drive Gear Motors Cast Iron

Turolia OpenCircuitGear™

TuroliaOCG, with more than 60 years of experience in designing and manufacturing gear pumps, gear motors and fan drive motors of superior quality, is the ideal partner ensuring robustness and reliability to your work functions.

We are fast and responsive - the first to specify a customer product, the most experienced in providing technical knowledge and support for fan drive solutions.

We offer a lean value chain to our partners and customers and the shortest lead time in the market.

TuroliaOCG is member of the Sauer-Danfoss Group.

Local address:

TuroliaOCG

Via Villanova 28
40050 Villanova di Castenaso
Bologna, Italy
Phone: +39 051 6054411
Fax: +39 051 6053033

TuroliaOCG

Kukučínova 2148-84
01701 Považská Bystrica, Slovakia
Phone: +421 424 301 544
Fax: +421 424 301 626

TuroliaOCG

2800 East 13th Street
Ames, IA 50010
USA
Phone: +1 515 239 6000
Fax: +1 515 239 6618